

Quick Rack™

Installation Manual

Patented Rail-Free Mounting System
for Composition/Asphalt Shingle Roofs



Quick Mount PV®
RESPECT THE ROOF

Table of Contents

Installation Instructions

| | | |
|-------|-----------------------------|----|
| I. | Quick Rack Components..... | 1 |
| II. | Quick Rack Assemblies..... | 2 |
| III. | Array Layout..... | 4 |
| IV. | Installing Mounts..... | 5 |
| V. | Leveling the Mounts..... | 7 |
| VI. | Installing the Clamps..... | 8 |
| VII. | Installing the Modules..... | 10 |
| VIII. | Wire Management..... | 11 |

Reference

| | | |
|----|--|--------|
| A. | General Requirements..... | Ref-1 |
| B. | Span Tables, Wind Exposure Category Table, and Rafter Attachment Figures..... | Ref-4 |
| C. | Code Compliance..... | Ref-14 |
| D. | UL2703 Compliance Requirements..... | Ref-15 |
| E. | System Specifications and Ratings..... | Ref-19 |
| E. | Engineering Drawings..... | Ref-20 |

I. Quick Rack Components

Quick Rack rail-free mounting system features QRack® technology. With only 3 main components and an optional skirt, the system works with standard module frames and features Quick Mount PV's high-quality, patented Elevated Water Seal to ensure a long, watertight life on the roof. Components are pre-assembled and ready for installation right out of the box.

1

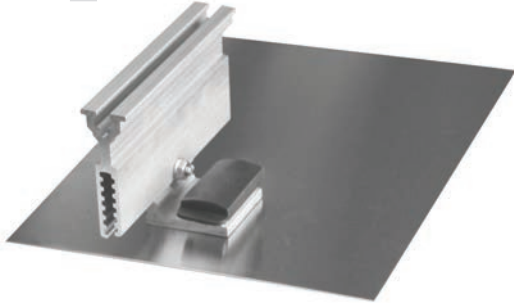

Base Mount

Featuring Quick Mount PV's patented Elevated Water Seal.

2

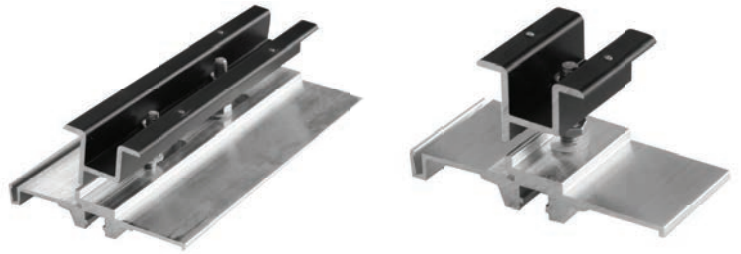

Panel Clamp

Available in two lengths (2" & 8") for mid-clamping, end-clamping, and module bridging that *work with standard module frames*.

3



Grounding Lug

Only one IISCO GBL-4DBT grounding lug per system is needed. Lug replaces cap screw in base mount top slider.

4 *Optional*



Skirt

Snaps right into place for an elegant, streamlined finish.

II. Quick Rack Assemblies

NOTE: Part quantities are per assembly. For part measurements see pages **Ref-20 - Ref-28** for engineering drawings.

Base Mount Assembly Parts

- A** Flashing x1
- B** QBlock Slider x1
- C** Top Slider x1
- D** Custom Hex Head Cap Screw x1
- E** Serrated Flange Hex Nut x1
- F** T-30/Hex Head Structural Screw, 5/16" x1
- G** EPDM/SS Sealing Washer x1
- H** EPDM Screw Cover x1

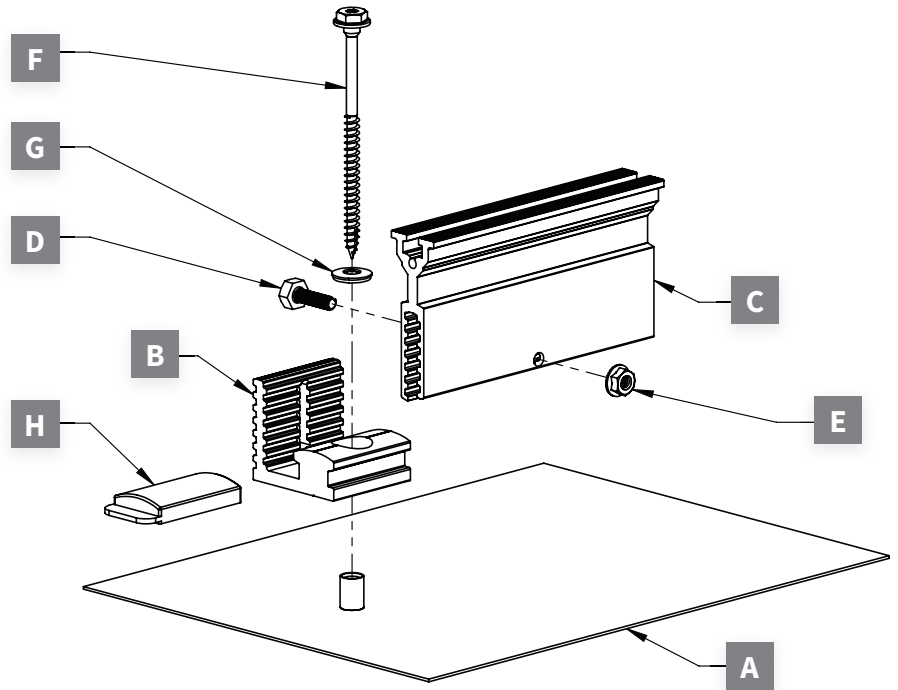

Skirt Assembly Parts

- A** Skirt x1
- B** Skirt Clip x2
- C** Skirt End Cap, Right x1
- D** Skirt End Cap, Left x1
- E** Sheet Metal Screw x4

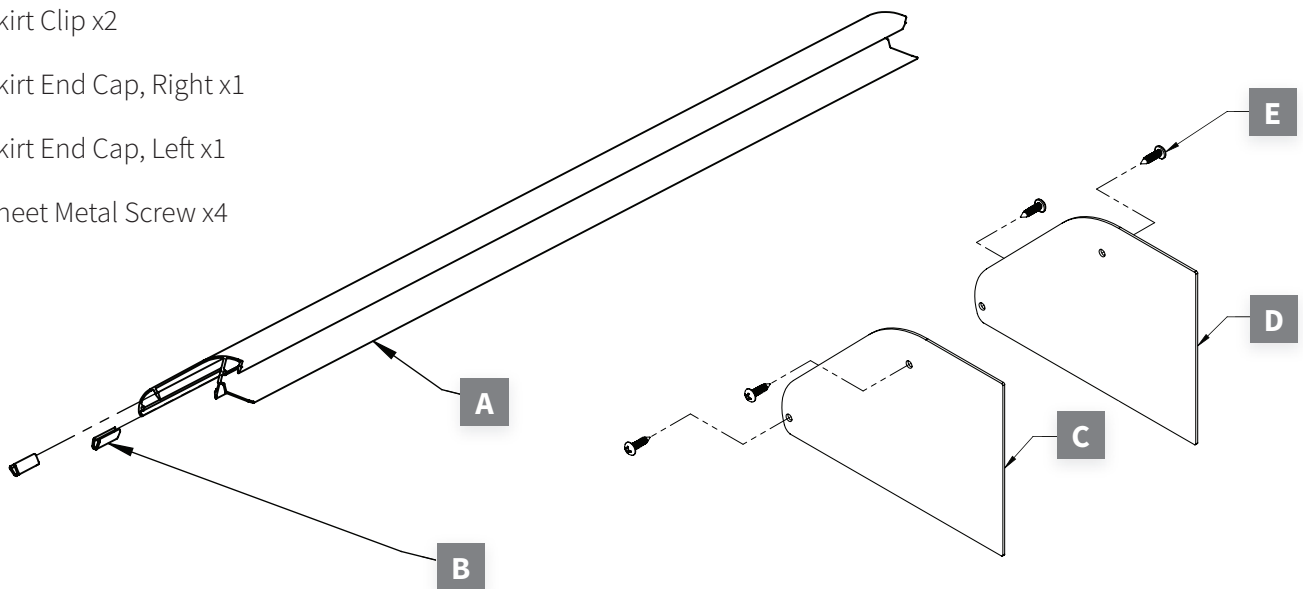

Panel Clamp Assembly Parts

- A** Clamp Base x1
- B** Panel Clamp (2" or 8") x1
- C** Hex Head Cap Screw x1 (x2 for 8")
- D** Plastic Retainer Ring x1 (2" clamp only)
- E** Hex Nut x1 (x2 for 8")
- F** Serrated Flange Hex Nut x1 (x2 for 8")
- G** Clamp Spring (8" clamp only)

2" Panel Clamp Assembly

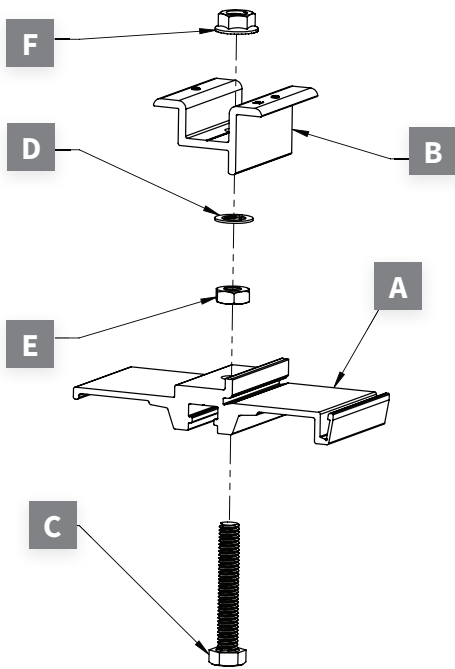

8" Panel Clamp Assembly

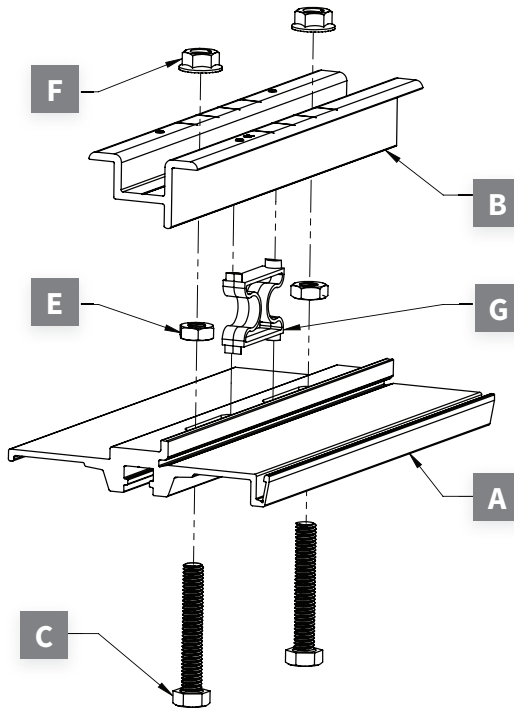

Grounding Lug Assembly Parts

- A** IlSCO GBL-4DBT Grounding Lug with Set Screw x1
- B** Slotted Stainless Steel Hex Head Cap Screw x1
- C** Star Washer Stainless Steel x1
- D** Serrated Flange Stainless Steel Hex Nut x1

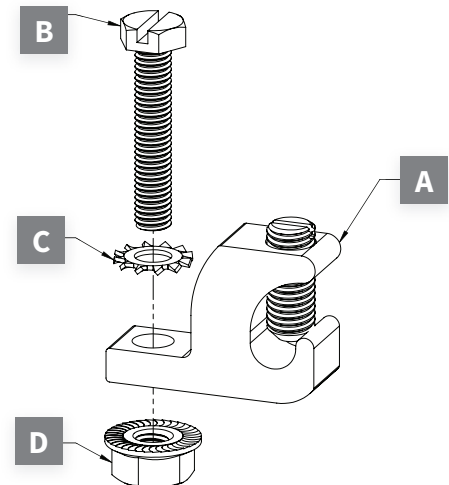

III. Array Layout

Using your engineered design, locate array layout on the roof, and determine mount locations. See pages **Ref-4 - Ref-14** for span tables, wind exposure categories, cantilevers, and engineering rules. See page **Ref-2** for alternative Snow Country Installation Requirements.



Locate rafters that will receive a mount. Identify the placement of the first row of mounts being aware that the skirt will overhang the front of the array by 6" and the uppermost flashings will be at least 3 courses down from the ridge.



Mark off the locations for the bottom row of mounts. The penetration point for the first row is typically 3" up from the butt of the shingle.

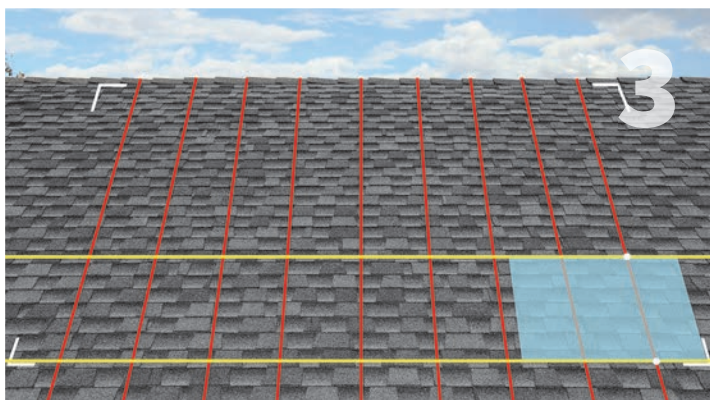

To determine the location for the next row of mounts, measure up from the penetration point the dimension of the module plus 1" for the clamp spacing.



By measuring up in this manner, you are locating the center point of the next mounts' penetration zone. Mark these points off with chalk.

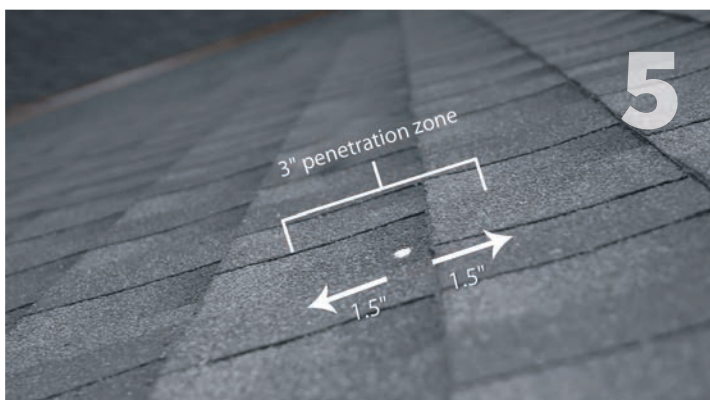

The penetration zone is a 3" range from 1.5" above to 1.5" below the center point. Cutting the shingles is acceptable, but can be avoided by moving the penetration point up or down by 1.5" from the center point.

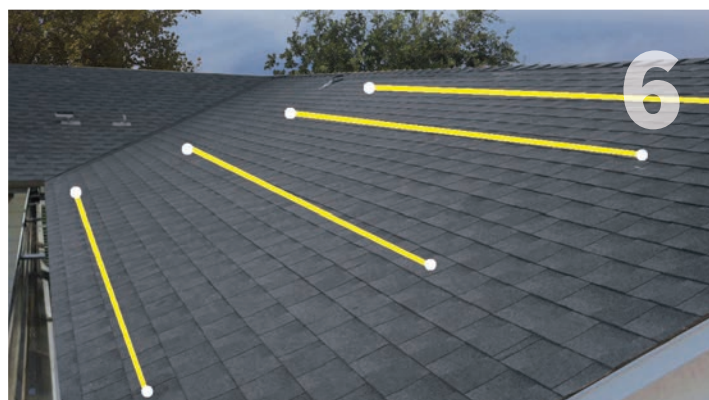

Snap lines at these locations as these measurements translate across the roof for the rest of the mounts.

IV. Installing the Mounts

Tool Specs: Drill, roofing bar, 1/8" x 6" drill bit, T-30 Torx bit or 1/2" socket, appropriate sealant

Torque Specs: Lag bolt = 13 ft-lbs in 65°F weather



Use roofing bar to break seals between 1st and 2nd, and 2nd and 3rd shingle courses. Be sure to remove all nails to allow correct placement of flashing. See page 6 for proper flashing placement.



Holding the drill square to the rafter, drill 3" deep pilot hole into center of rafter using 1/8" aircraft extension bit.



Fill pilot hole with appropriate sealant.



Optional: Apply an upside down U-shaped bead of sealant to the underside of the flashing before insertion. Do not use excessive sealant.



Slide the base mount up underneath the second course of shingles, so that the bottom edge of the flashing does not overhang the butt edge of shingles.



Be sure to orient the top slider to either the left or right, except where needed at cantilevers and bridge gaps, according to your design and to comply with engineering best practices.



Swivel the base mount to gauge proper torque when driving the lag bolt. Tighten until mounting block stops swiveling easily. (In 65°F weather, this would equal 13 ft-lbs.)

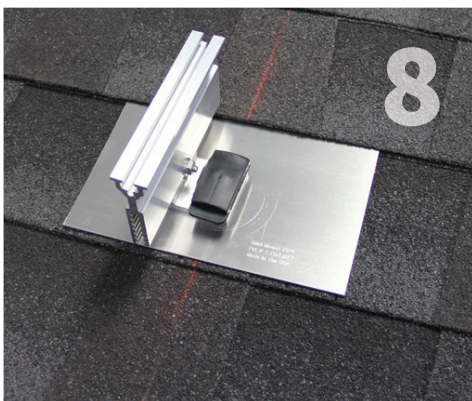

Cap the mounting block with the EPDM rubber cover.



Repeat steps 1-8 to install all mounts

WARNING: These products are NOT designed for and should NOT be used to anchor fall protection equipment.

Additional Tips and Information

- It is not necessary or advisable to use nails or other fasteners to secure the perimeter of the flashing.
- The Base Mount is made to work with standard and high-definition composition/asphalt and wood shingle roofs with 5" to 5-5/8" courses.
- Depending on the season and climate, size and location of seal tabs, and quality of the shingles, the seal tabs that adhere the shingle courses together may not effectively seal the shingles to the flashings. If this is the case, simply add several quarter-sized dabs of manufacturer accepted sealant or asphalt roofing cement, meeting ASTM D 4586 Type II, between the flashing and the shingle above.
- Mounts should not be installed in areas of the roof susceptible to ice damming. Ponding water can travel upward under shingles and reach the bolt penetration.
- Take care not to damage the roofing material while working on the roof. Removing stone granules and deforming the shingles in any way can shorten the lifespan of the roofing. The value of the solar array is directly affected by the condition of the roof it is attached to.

Proper Flashing Placement

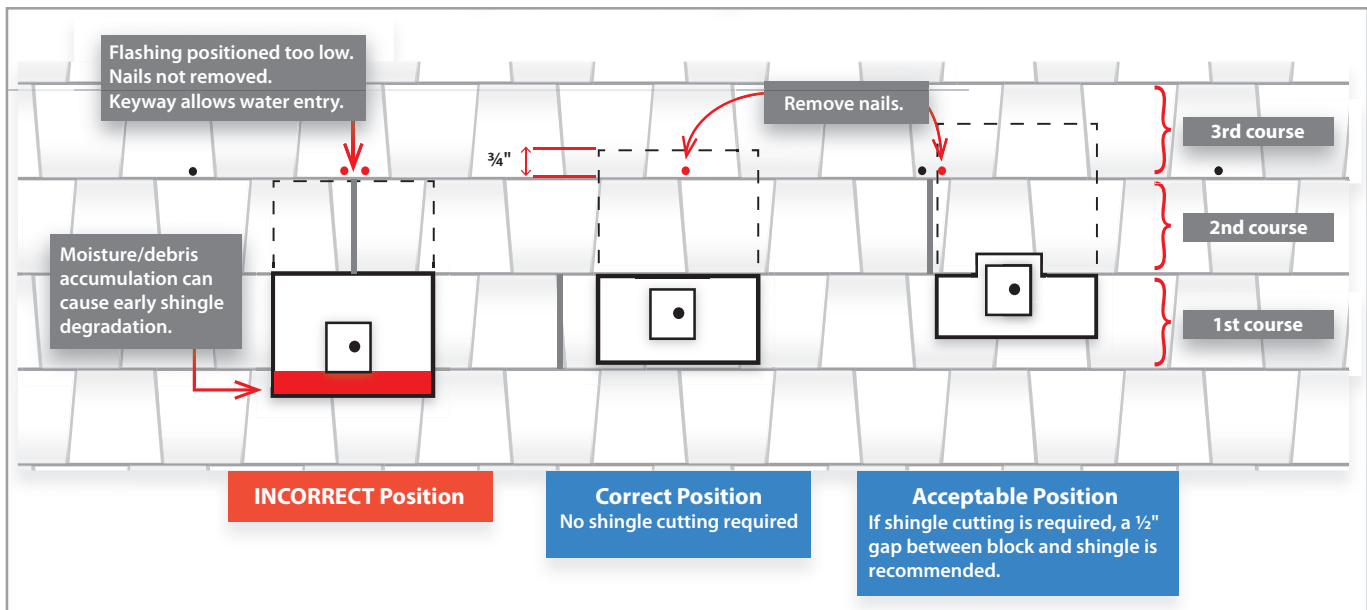

V. Leveling the Mounts

Tool Specs: 1/2" socket and wrench

Torque Specs: Top slider bolt = 6 ft-lbs minimum

The modules in the Quick Rack system are unified by rigid panel clamps into a single flush surface, so small dips and curves in the roofs surface may not be visually apparent. However, mounts that are close together should be level with each other. To reduce time on the roof, use your own judgment about where a dip is significant enough to require leveling to maintain a smooth looking surface. See page **Ref-2** for alternative Snow Country height requirements.

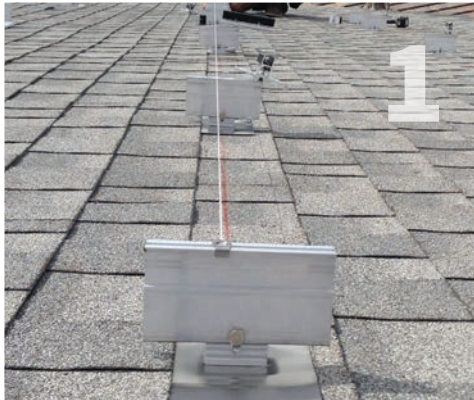

1 Run a string line between the first and last mounts in the first row.



2 The string acts as a guide for aligning the top slider positions of all the mounts in the row. To adjust top slider height, remove machine bolt, separate top slider from QBlock slider and reinsert at proper location.



3 To adjust in 1/4" increments move the top slider up or down one notch. To adjust in 1/8" increments rotate the top slider 180 degrees. Repeat for the other mounts until top slider elevations are uniform across the row.

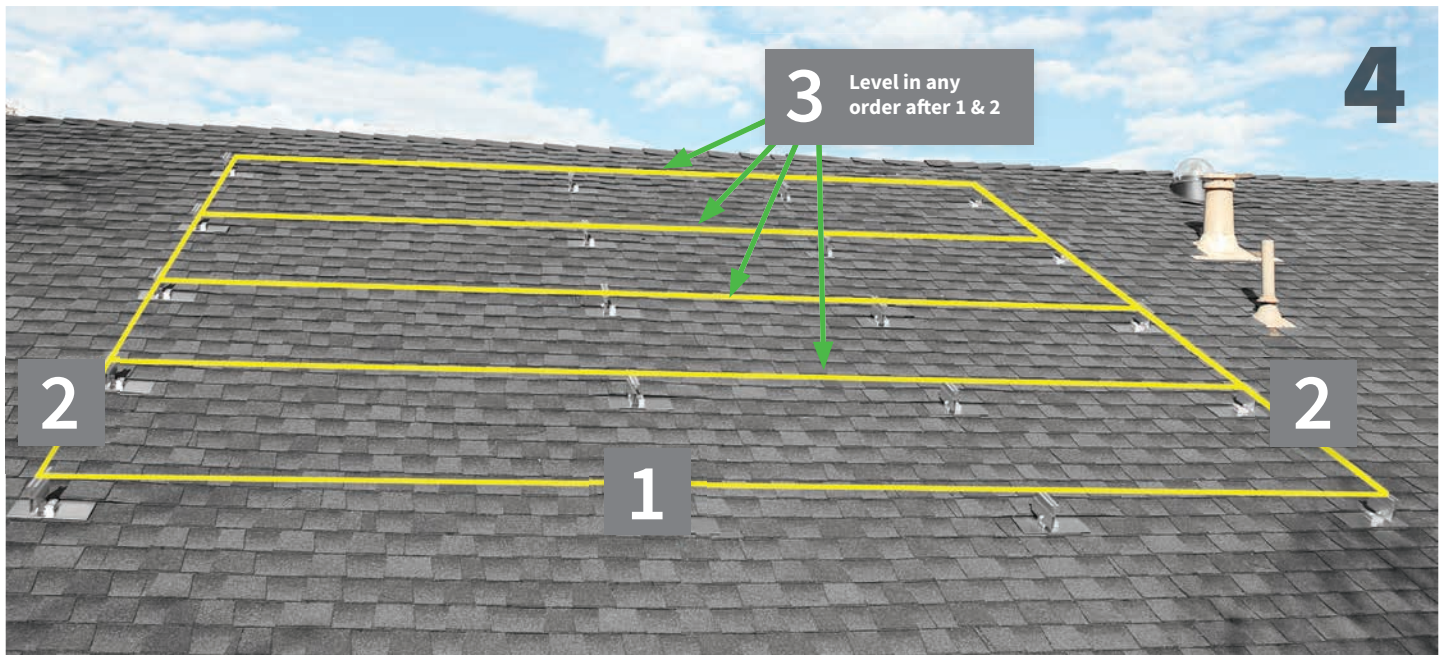

4 After aligning the first row horizontally, follow the same string alignment process vertically on far right and far left columns. Then align each remaining row of the array (in any order).

VI. Installing the Clamps

Tool Specs: 1/2" box wrench

The modules are connected to the base mounts using 2" panel clamps, which can act as both mid clamps or end clamps, see step 3. The 8" panel clamps are used to bridge modules together. 8" panel clamps can either be floating, or attached to a base mount when the rafters align with a module intersection. Panel clamps include integrated grounding pins. See page **Ref-17** for grounding information.

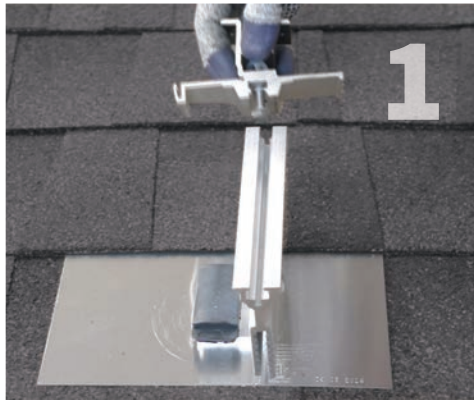

Install all panel clamp assemblies. The bolt head underneath the clamp lines up and slides into the channel on the top of the slider of the base mount.



The spring in the 8" panel clamp allows you to engage either one of the bolts by pressing down the top clamp above the bolt. With the bolt head engaged it slides into the channel on the top of the slider.

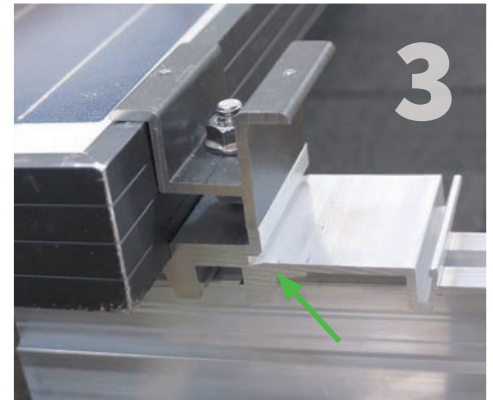

When the 2" or 8" clamp is used as an end clamp in either front or back row, be sure that the long leg on the panel clamp aligns with the short leg on the panel base and is oriented away from the module as shown above.

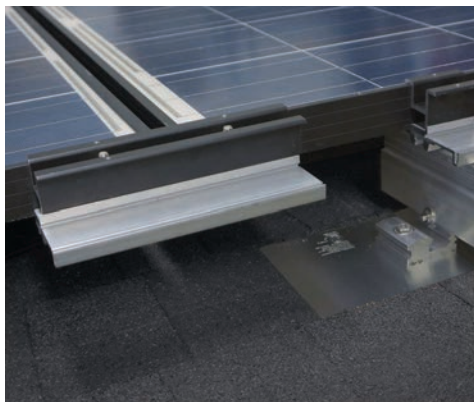

In most cases, 8" clamps are used to structurally bridge together modules with no base mount. However, if a rafter lines up with a base mount, it is also acceptable to use an 8" clamp attached to base mount to bridge modules together.



Install 8" clamp in the correct orientation depending on your array design and the location of the module intersection.

Installing the Clamps & Skirt in the First Row

Only the front row needs to be aligned and locked down in order to assure a straight and secure skirt and array. All other panel clamps in the following rows do not need to be aligned or locked into the base mounts. See page **Ref-2** for alternative Snow Country Installation Requirements.

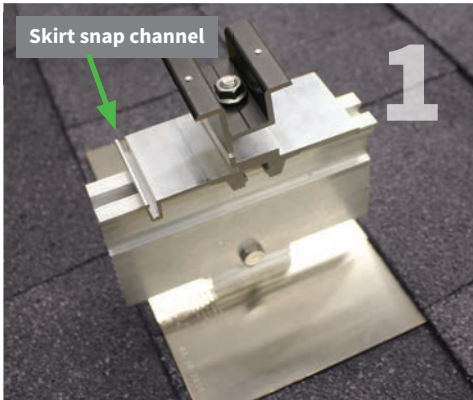

For the first row, clamp must be oriented with skirt snap channel in downslope position.



Use 1/2" box wrench on mid-clamp assembly nut to tighten clamps to first and last (far left and right) top sliders.



Align first row of clamps using a string line. Tighten all aligned first row clamps using the 1/2" wrench.



Match the skirt cantilever to the module cantilever based on your array design.

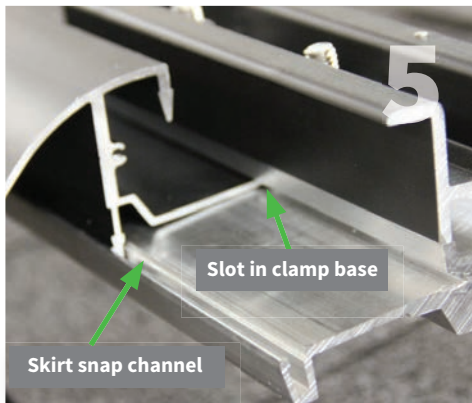

Insert horizontal leg of the skirt into slot in clamp base, then snap the skirt down in skirt snap channel.



Slide 8" bridge clamps onto the skirt segments at the module intersections. Slide the clamp about halfway onto one side of the skirt, and then slide the next segment of the skirt onto the other side of the clamp, finishing by sliding the skirts flush together.

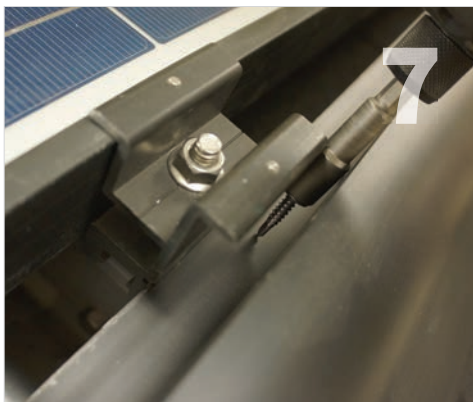

Optional: Supplement skirt attachment by screwing horizontal leg of skirt to horizontal leg of clamp base using a #10 x 5/8" long stainless steel, self drilling, sheet metal screw.

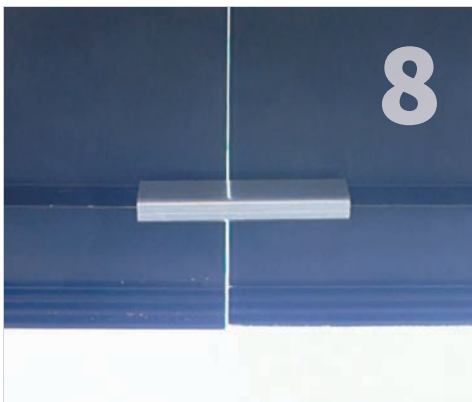

Install remaining skirt sections. Use skirt clips as needed to maintain alignment at skirt junctions.



Skirt is optional but acts as an installation aide.

VII. Installing the Modules

Tool Specs: 1/2" socket and wrench or drill

Torque Specs: Panel Clamp = 13 ft-lbs minimum/20 ft-lbs maximum



Insert the bottom edge of the module frame into the lower clamps. The top of the module sits on the lower portion of the clamp assembly for the row above.



Where 2, 3, or 4 modules need to be connected, slide the 8" panel clamp over the module frame. The 8" clamp can either be floating or attached to base mount if the rafters line up. See below for proper module gap and clamp placement.



When the first row of modules is in place, tighten down the panel clamps to a torque setting of 13 ft-lbs in the bottom row only using a 1/2" socket on a drill or a torque wrench. **DO NOT USE AN IMPACT GUN.**

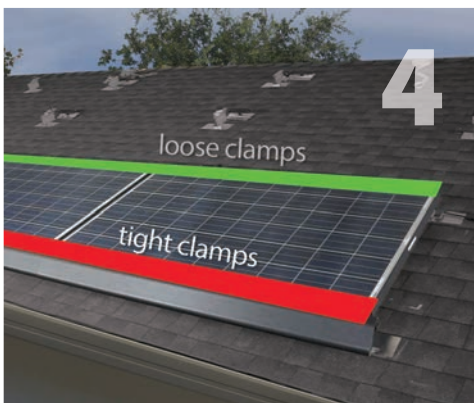

The upper row of clamps should remain loose to accept the next row of modules.



Complete wire management for the first row (see section VIII) and then continue installing modules for all rows, completing wire management for each row as it is installed, then tightening the lower edge of each successive row.

Module Gap and Clamp Placement

Preferred

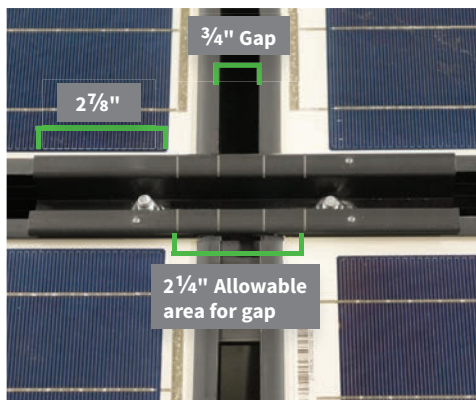

Acceptable

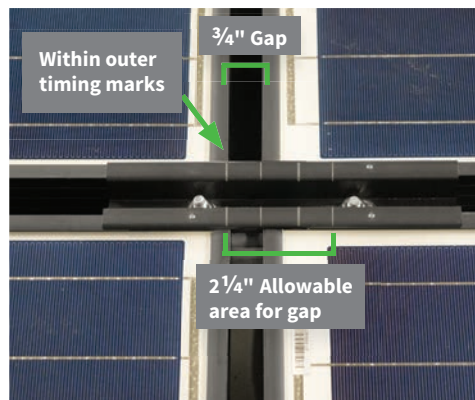

Unacceptable

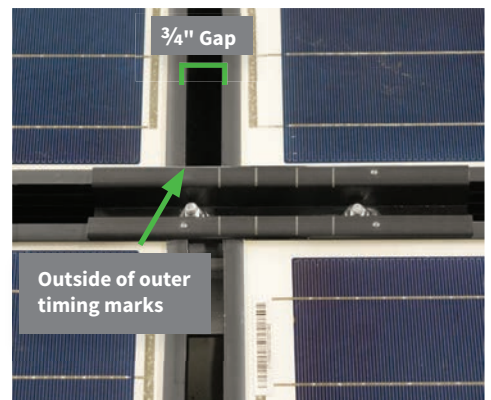

The edge of the module frames must not sit outside the 2 1/4" allowable range indicated by the outer timing marks. The inner set of timing marks show the 3/4" gap centered in the allowable space.

VIII. Wire Management

Tool Specs: Wire clips, flat head screw driver

Torque Specs: Grounding lug bolt = 35 in-lbs, grounding lug set screw - see page **Ref-19**



Complete wire management on a row-by-row basis. With a two man crew, wire management and clamp tightening can be done at the same time.



Before connecting the modules together, be sure to position one of the PV wires out to serve as the homerun connection.



Connect the module leads together and tuck the wires inside the module frame with wire clips on each side of the connectors.



Clip wires to the **inside** of the module frame. Repeat this process across the row of modules. If there is remaining slack in the PV wires, use additional clips to keep wires off the roof surface.

Wire Management Recommendations

See pages 12-14 for suggested wire configuration, clip placement, and product recommendations.

Installing the Grounding Lug



The system only requires one Ilco GBL-4DBT grounding lug. Replace the cap screw in any base mount top slider with grounding lug hardware, assembled per the diagram on page 3.



Secure your wire to the lug by tightening the set screw.

Wire Configuration and Clip Placement

Suggested Landscape Configuration

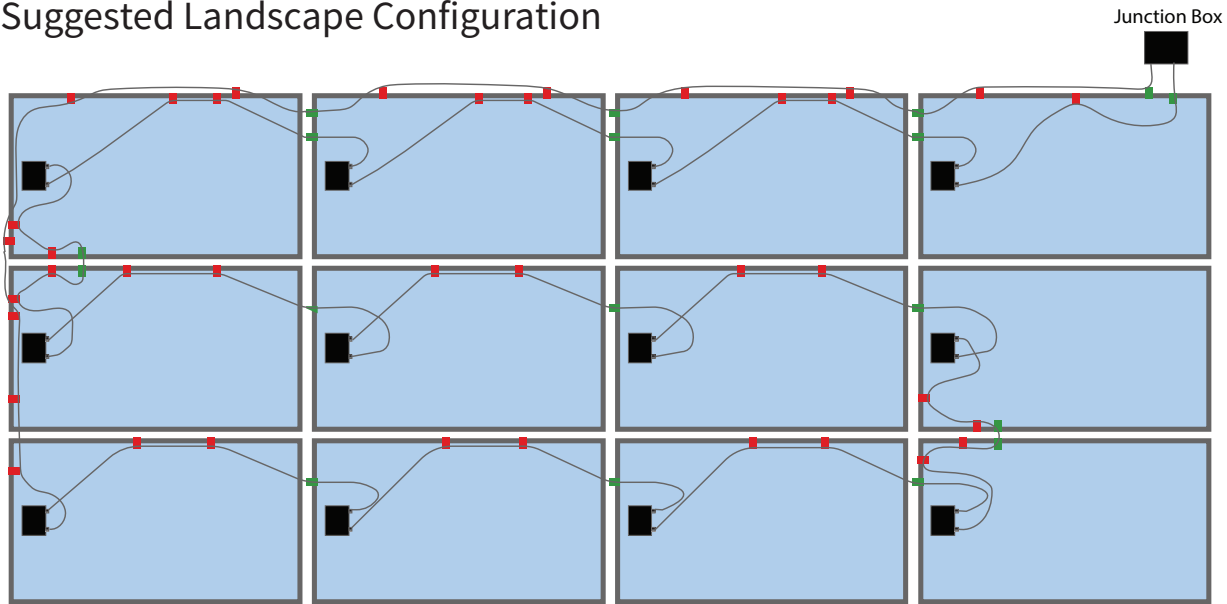

Suggested Portrait Configuration

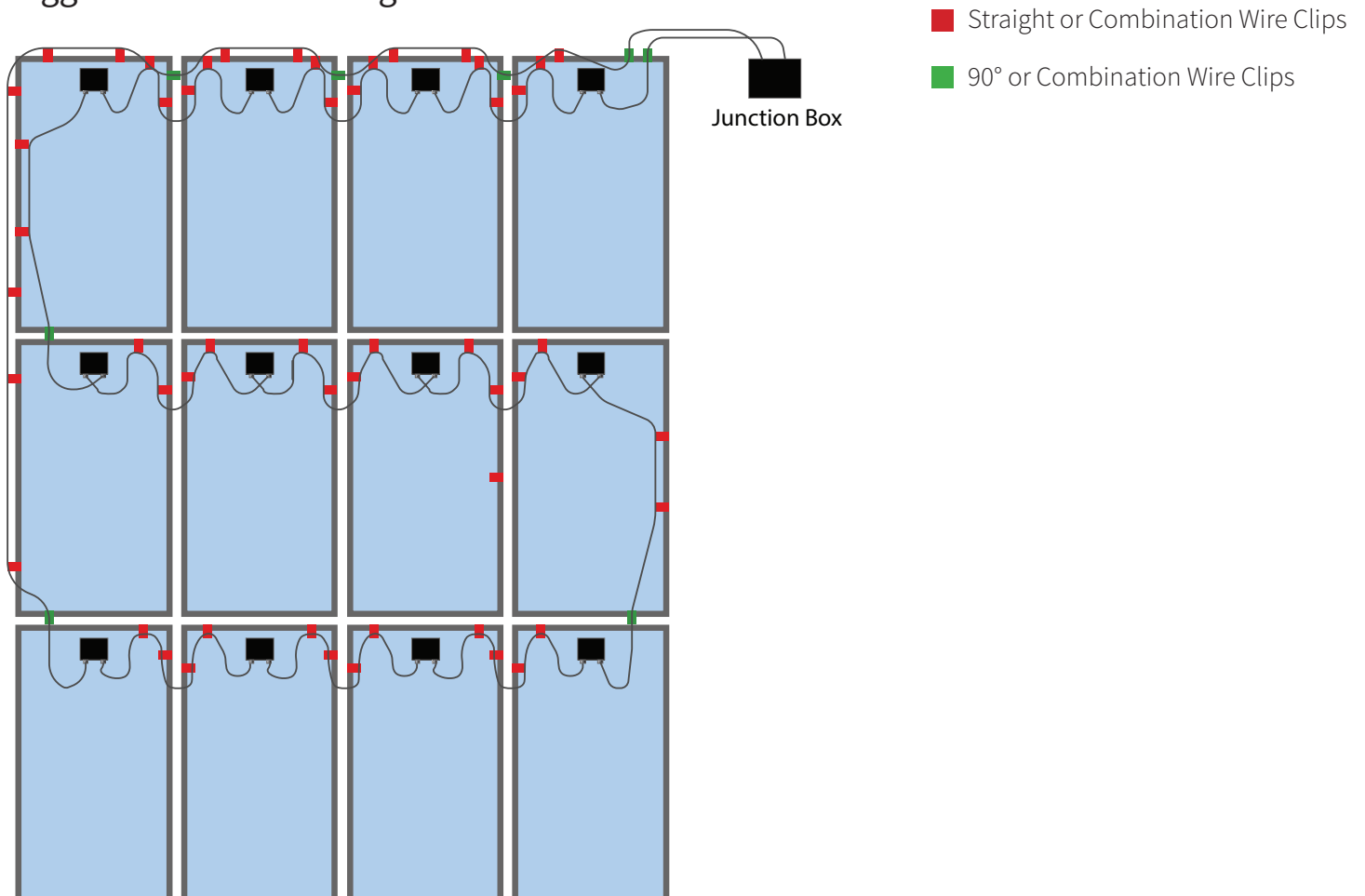

Suggested Micro-Inverter Landscape Configuration

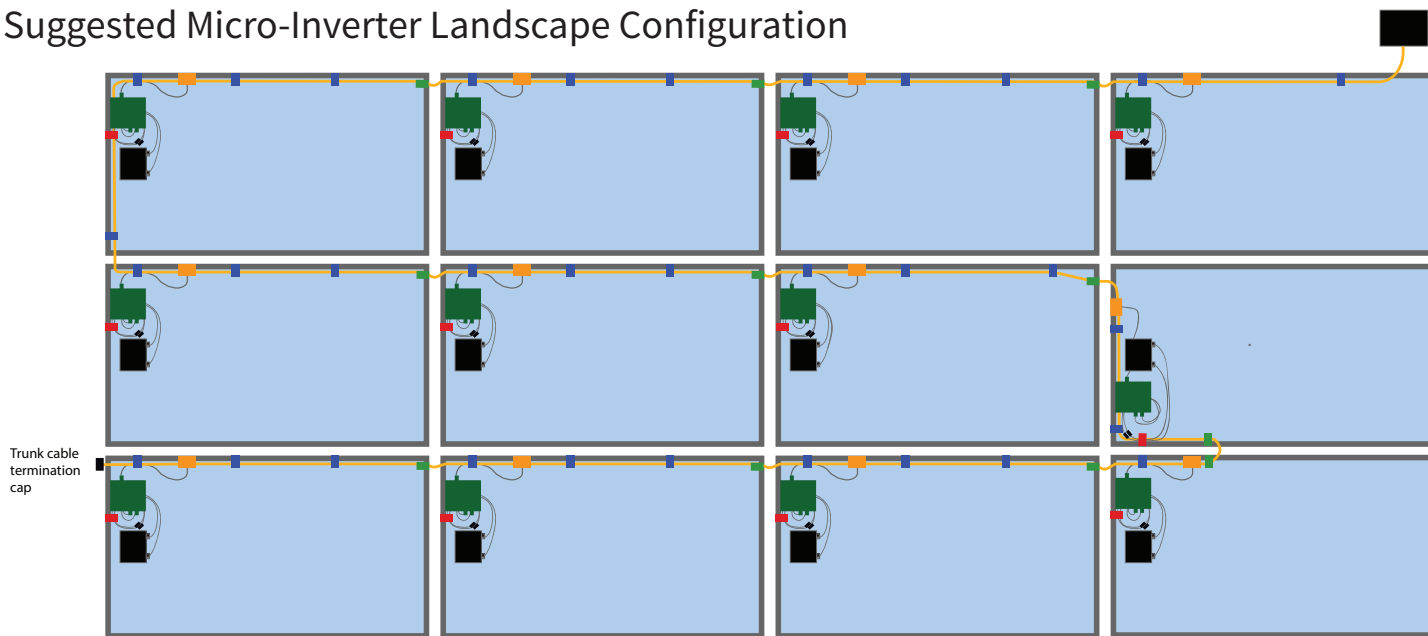

Suggested Micro-Inverter Portrait Configuration

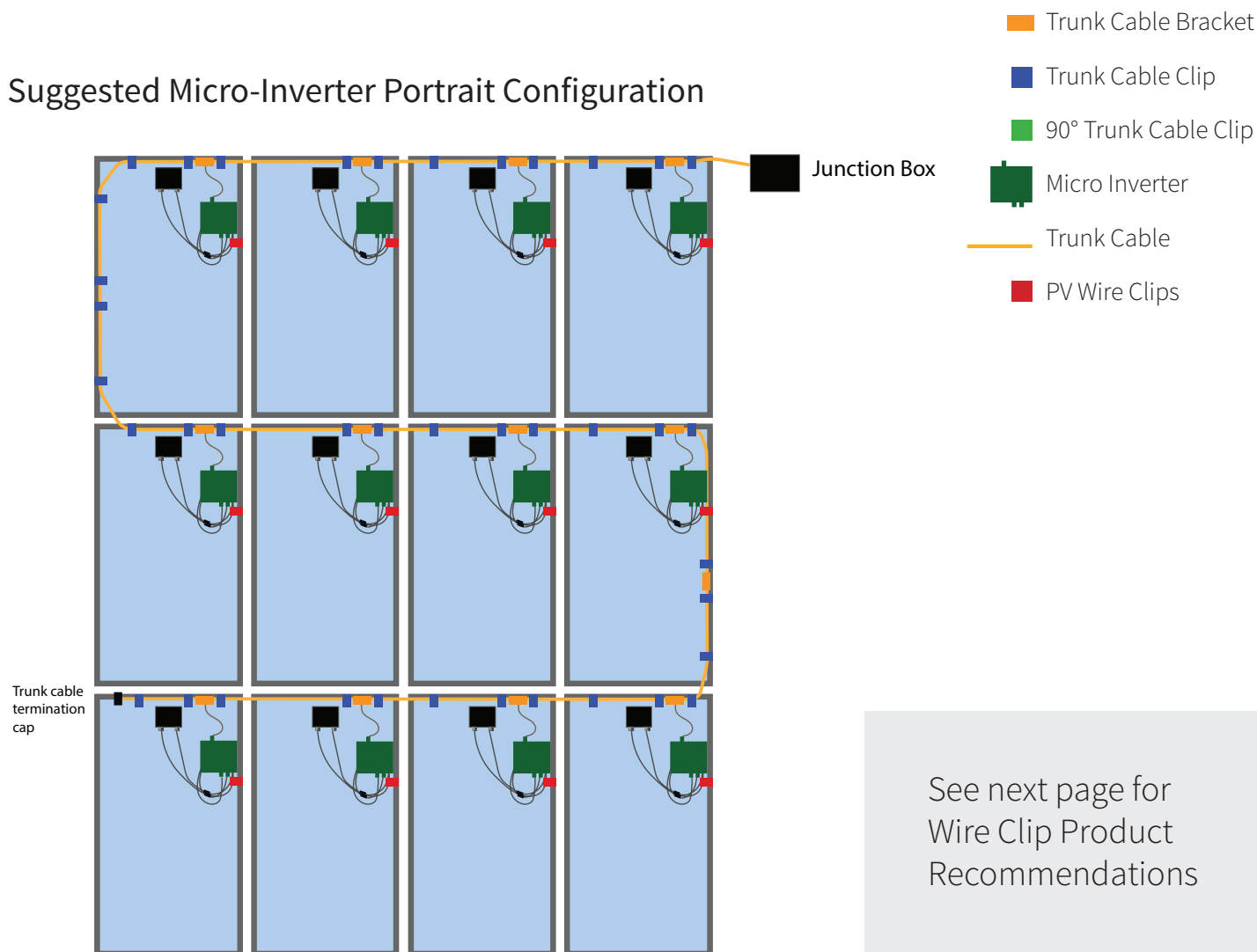

See next page for
Wire Clip Product
Recommendations

Wire Clip Recommendations

Rail-free systems are dependent on wire management clips that hold securely to both the wires and the module frames. After extensive testing, we recommend the following products with this system.

| Cable/Wire Type | Straight Clips | 90° Clips | Straight and 90° Combo Clips |
|------------------------|---------------------------------|---------------------------------|-------------------------------------|
| String Inverter | Nine Fasteners DCS 1307 | Heyco® Sunrunner® 90° | Wiley/Burndy® ACC-F90-1 |
| Microinverter | Nine Fasteners NFI-1463 | Wiley/Burndy® ACC-FBC w/Unirap™ | Wiley/Burndy® ACC-FBC w/Unirap™ |
| Cable Bundles | Wiley/Burndy® ACC-FBC w/Unirap™ | Wiley/Burndy® ACC-FBC w/Unirap™ | Wiley/Burndy® ACC-FBC w/Unirap™ |

For questions contact us at tech@quickmountpv.com or call (925) 478-8269.

Reference

A. General Requirements

The Span Tables, Wind Exposure Category Table, and Rafter Attachment Pattern Figures beginning on page **Ref-4** are subject to the requirements shown in the table footnotes and to the following criteria. See **Quick Rack V1.1-2 Base Mount Code Compliance Report** dated 7-24-2015 by Mar Structural Design if additional information is required.

Region and Site

- The roof is not in a special topographic region subject to wind speed-up effects, such as near or at the crest of a tall ridge or hill (i.e. ASCE 7 topographic factor of 1.00). Refer to ASCE 7-10 Sec. 26.8 for determining if a roof is in a special wind speed-up zone.
- The building is not a special occupancy structure such as a public school, public safety building or assembly building (i.e. the ASCE 7-10 importance factor is 1.00 for snow and seismic loads, and the building is Risk Category II for wind loads).
- In general, Quick Rack base mount capacity exceeds seismic lateral demands in almost all areas of the United States. The tables list minor limitations in unusual regions where combined high snow and seismic loads may occur.

Roof Characteristics

- The installation is on wood-framed roofs with composition shingle, wood sawn shingle, built-up roofing, or membrane roofs, underlain by plywood, oriented strand board or solid 1x sheathing.
- The existing roof structure should be generally code-compliant, and should not show signs of decay, fire damage, significant added dead loads, structural modifications (such as removal of web members from carpenter trusses) or any other condition that may weaken its load-carrying capacity. If there is doubt about the suitability of the roof to carry the new PV array, a qualified licensed engineer should be retained to inspect and analyze the existing roof structure.
- The PV array is installed on the roof of an enclosed building with a mean roof height less than or equal to 35 feet. The mean roof height is defined as the average height of the roof eave and the highest point on the roof.
- The roof pitch is between 2:12 (9.5 degrees) and 12:12 (45 degrees).
- Rafters have a minimum nominal width of 2" (1.5" actual width) and have a specific gravity of 0.42 or greater, allowing lumber species groups that range from relatively lightweight, such as Spruce-Pine-Fir, Hem-Fir and Close Grain Redwood, to denser woods such as Douglas Fir and Southern Pine.
- In existing construction, rafters are dry and seasoned. In new construction, rafters are either Kiln-Dried (KD) or Surfaced Dry (S-DRY), or, if Surfaced Green (S-GRN), have an in-field measured moisture content of 19% or less.

Installation Specifics

- The maximum short edge panel width for PV modules installed in landscape orientation is 40".
- The maximum long edge panel length for PV modules installed in portrait orientation is 66".

Installation Specifics, cont'd

- Each Quick Rack base mount is fastened to the roof rafter with one 5/16" nominal diameter structural screw, defined as either a 5/16" nominal diameter GRK RSS screw with Climatek coating or a 5/16" nominal diameter QMPV Dual-Drive screw, each pre-drilled with an 1/8" pilot hole to prevent splitting. The structural screw shall be embedded at least 2.5" into the roof rafter. The structural screw shall be torqued to achieve a snug fit of the mount to the flashing (the QBlock Slider should not be able to rotate easily).
- For all PV module orientations, the Quick Rack base mount Top Slider tracks are positioned parallel to roof slope and connect to the module edges that run perpendicular to the slope. Alternate mounts so that approximately 50% of the base mount "elevated seal regions" (toes) point in the nominal west (left cross-slope) direction with the remainder pointing in the opposite direction. Exceptions are allowed at cantilevers and at bridge clamps between modules.
- The PV modules shall be clamped to the Quick Rack track using the provided two-part clamp (clamp base and panel clamp) and a 5/16" stainless steel (grade 18/8) machine bolt, **torqued to no less than 13 ft-lbs and no more than 20 ft-lbs**. For zero and low snow regions, the center of the machine bolt into the top slider shall be installed no more than 1.5" upslope or downslope from the center of the top slider. Machine bolts may be installed in any position along the slots in the 8" clamp.
- Snow country additional requirements must be followed when ground snow load is 21 psf or greater for landscape orientation and 16 psf or greater for portrait orientation. See ***Snow Country Installation Requirements*** below.
- The maximum PV mount and module cantilevers are defined in Figure 4 and enumerated in Tables 1B, 1C, 2B and 2C.
- Per AC-428, the upslope and downslope edge of the PV array shall be no closer than 10" to the eave or ridge of the roof. Per Tables 1B, 1C, 2B and 2C, the sides of the array shall be no closer than 12" to the gable end, rake or hip edges of the roof (and more than 12" where required by the tables to achieve greater cantilever lengths).
- To prevent excessive snow build-up, where the ground snow load exceeds 10 psf, the top edge of the PV array shall be set no farther than 5 feet from the roof ridge, measured perpendicular to the ridge. Note that local fire jurisdictions sometimes require that the top edge of the array be set no closer than a certain distance (often 3 feet) to the ridge.
- If a skirt is installed along the bottom and/or top edge of an array, the gap between bottom of skirt and top of roof surface shall be at least 1/2". Nominal left and right edges of the array shall remain open.
- The dead load of the PV array (sum of the PV modules and Quick Rack base mount hardware) shall not exceed 3.5 psf.
- This code compliance report is limited to base mount structural performance. The modules installed in combination with Quick Rack shall also have UL 1703/2703 rated load capacities appropriate for the site's wind and snow loads.
- In regions subject to freezing, mounts must not be located in roof areas of potential ice dams.
- In regions subject to snow loads, modules are not permitted in roof areas prone to snow drift.

Snow Country Installation Requirements

- "Snow Country" are regions with the following ground snow loads:
 - 21 psf or greater, for arrays with modules in landscape mode.
 - 16 psf or greater, for arrays with modules in portrait mode.
- See Figure 2B on page **Ref- 9** for restrictions on downslope positions of clamps and maximum heights of mounts, as also described below.

Snow Country Installation Requirements, cont'd

- Clamp position on top slider(+/- 1/8" installation tolerance):
 - At any bottom row of mounts, clamps shall be installed on top sliders so that the center of the machine bolt into the top slider is 1.5" upslope from the center of the top slider.
 - For subsequent rows of mounts, clamps shall be installed so that the center of the machine bolt into the top slider shall be installed no more than 1.5" upslope or 1.0" downslope from the center of the top slider.
- Height of mounts (measured from bottom of mount to top of top slider):
 - Default factory mount height: 4.0" from bottom of mount to top of top slider.
 - At the bottom row of mounts, full height +/- 0.5" adjustability is allowed (mount height = 3.5" to 4.5")
 - For subsequent rows of mounts, mount height shall be no higher than 4.0" (default factory height), so that mounts can only be adjusted to be 0.5" shorter (mount height = 3.5" to 4.0").
- Note: These requirements will alter the steps for determining the location of the second row of mounts in the array layout (see page 4).
 - After marking the locations of the first row of mounts in your layout, measure up the rafter from the penetration point the width/length of the module plus 2.5". This is the center point of the penetration zone of the second row of mounts.
 - The snow country penetration zone is 1" downslope from center and 1.5" upslope from center, for a range of 2.5".
 - For the remainder of the rows the penetration zone center point will be module width/length plus 1" upslope from previous row, follow penetration zone range above.

B. Span Tables, Wind Exposure Category Table, and Attachment Figures

Use the tables and Figures on the following pages to determine mount spacing for your array layout design.

Table 1A. Quick Rack Base Mount Maximum Spacing, Modules in Landscape Orientation

| Wind Speed ASCE 7-05 (Service Level) | | ASCE 7-10 (Strength Level) | Roof Pitch | Ground Snow Load | | | | | | | | | | | | | | | | | | | |
|--|---------------|-------------------------------|------------|------------------|-----|-----|-----|-------------|-----|-----|-----|-------------|-----|-----|-----|-------------|-----|-----|-----|-------------|---|--|--|
| | | | | 0 - 20 psf | | | | 21 - 30 psf | | | | 31 - 40 psf | | | | 41 - 50 psf | | | | 51 - 60 psf | | | |
| | | | | B | C | D | B | C | D | B | C | D | B | C | D | B | C | D | B | C | D | | |
| 85 mph | 2:12 to 6:12 | 110 mph | 72" | 72" | 72" | 72" | 72" | 72" | 72" | 72" | 72" | 72" | 72" | 72" | 72" | 72" | 72" | 72" | 72" | | | | |
| | | | 48" | 48" | 48" | 48" | 48" | 48" | 48" | 48" | 48" | 48" | 48" | 48" | 48" | 48" | 48" | 48" | 48" | 48" | | | |
| 90 mph | 2:12 to 6:12 | 115 mph | 72" | 72" | 72" | 72" | 72" | 72" | 72" | 72" | 72" | 72" | 72" | 72" | 72" | 72" | 72" | 72" | 72" | | | | |
| | | | 48" | 48" | 48" | 48" | 48" | 48" | 48" | 48" | 48" | 48" | 48" | 48" | 48" | 48" | 48" | 48" | 48" | 48" | | | |
| 95 mph | 2:12 to 6:12 | 120 mph | 72" | 72" | 72" | 72" | 72" | 72" | 72" | 72" | 72" | 72" | 72" | 72" | 72" | 72" | 72" | 72" | 72" | | | | |
| | | | 48" | 48" | 48" | 48" | 48" | 48" | 48" | 48" | 48" | 48" | 48" | 48" | 48" | 48" | 48" | 48" | 48" | 48" | | | |
| 100 mph | 2:12 to 6:12 | 130 mph | 72" | 72" | 72" | 72" | 72" | 72" | 72" | 72" | 72" | 72" | 72" | 72" | 72" | 72" | 72" | 72" | 72" | | | | |
| | | | 48" | 48" | 48" | 48" | 48" | 48" | 48" | 48" | 48" | 48" | 48" | 48" | 48" | 48" | 48" | 48" | 48" | 48" | | | |
| 110 mph | 2:12 to 6:12 | 140 mph | 72" | 72" | 72" | 72" | 72" | 72" | 72" | 72" | 72" | 72" | 72" | 72" | 72" | 72" | 72" | 72" | 72" | | | | |
| | | | 48" | 48" | 48" | 48" | 48" | 48" | 48" | 48" | 48" | 48" | 48" | 48" | 48" | 48" | 48" | 48" | 48" | 48" | | | |
| 120 mph | 2:12 to 6:12 | 150 mph | 72" | 72" | 72" | 72" | 72" | 72" | 72" | 72" | 72" | 72" | 72" | 72" | 72" | 72" | 72" | 72" | 72" | | | | |
| | | | 48" | 48" | 48" | 48" | 48" | 48" | 48" | 48" | 48" | 48" | 48" | 48" | 48" | 48" | 48" | 48" | 48" | 48" | | | |
| | 7:12 to 12:12 | | 72" | 72" | 72" | 72" | 72" | 72" | 72" | 72" | 72" | 72" | 72" | 72" | 72" | 72" | 72" | 72" | 72" | | | | |
| | | | 48" | 48" | 48" | 48" | 48" | 48" | 48" | 48" | 48" | 48" | 48" | 48" | 48" | 48" | 48" | 48" | 48" | 48" | | | |

Table Notes:

1. The Quick Rack base mount maximum allowable spacing listed in this table is the spacing between base mount attachment points in the roof cross-slope direction for modules in landscape orientation.
2. This table is based on an assumed PV module size no larger than 40" x 66".
3. See Figure 4 and Tables 1B and 1C for the maximum mount cantilever (clamp bolt to end-of-module) at the nominal east or west edge of array (cross-slope edge of roof).
4. This table is subject to the conditions stated in the attached Code Compliance Letter, and shown in the attached sketches.
5. This table is based on ASCE 7-10. ASCE 7-05 wind speeds are back-calculated from ASCE 7-10 wind speeds to produce the same wind pressures, rounded to nearest 5 mph.
6. Wind load calculations are based on a Risk Category II building with a mean roof height of 35 feet and $I_w = 1.0$.
7. Snow load calculations are based on $C_e = 1.0$, $I_s = 1.0$, $C_d = 1.2$ and ASCE 7-10 Fig. 7-2a for unobstructed slippery surface (ref. ASCE 7-10 Commentary C7.8)
8. See Table 3 for regions of high wind or snow load where a staggered base mount layout is recommended.
9. The roof pitch range "2:12 to 6:12" corresponds to 9 to 27 degree roof slopes; the roof pitch range "7:12 to 12:12" corresponds to 27.1 to 45 degree roof slopes.
10. Mount capacities are based on ICC AC-13, and are not increased for load duration factor per the restrictions of AC-13. See Appendix 1 for additional information.
11. For locations with an unusual combination of both high seismic and snow loads, see Appendix 2, Table A2.1.

Table 1B. Quick Rack Base Mount Maximum East and West Cantilevers, Modules in **Landscapes** Orientation with Typical Backspan from Table 1A

| Wind Speed (Service Level) | ASCE 7-10 (Strength Level) | Typical Span (see Table 1A) | | | | | | Maximum Mount Cantilever with Backspan = Typical Span | | | | | | | | | | |
|-------------------------------|-------------------------------|--------------------------------|-----|-----|---------------------------|------------------------|-----|---|-----|------------------------|--------------------------|-----|-----|--------------------------|-----|-----|-----|-----|
| | | Roof Pitch | | | Roof Edge Distance = 36"+ | | | Roof Edge Distance = 24" | | | Roof Edge Distance = 18" | | | Roof Edge Distance = 12" | | | | |
| | | Wind Exposure Category | B | C | D | Wind Exposure Category | B | C | D | Wind Exposure Category | B | C | D | Wind Exposure Category | B | C | D | |
| 85 mph | 110 mph | 7:12 to 6:12 | 72" | 72" | 72" | 24" | 24" | 24" | 24" | 24" | 21" | 21" | 21" | 18" | 18" | 18" | 18" | |
| | | | 64" | 64" | 64" | 24" | 24" | 24" | 24" | 24" | 21" | 21" | 21" | 18" | 18" | 18" | 18" | 18" |
| | | | 72" | 72" | 72" | 24" | 24" | 24" | 24" | 24" | 21" | 21" | 21" | 18" | 18" | 18" | 18" | 18" |
| 90 mph | 115 mph | 7:12 to 6:12 | 72" | 72" | 72" | 24" | 24" | 24" | 24" | 24" | 21" | 21" | 21" | 18" | 18" | 18" | 18" | |
| | | | 64" | 64" | 64" | 24" | 24" | 24" | 24" | 24" | 21" | 21" | 21" | 18" | 18" | 18" | 18" | 18" |
| | | | 72" | 72" | 72" | 24" | 24" | 24" | 24" | 24" | 21" | 21" | 21" | 18" | 18" | 18" | 18" | 18" |
| 95 mph | 120 mph | 7:12 to 6:12 | 72" | 72" | 72" | 24" | 24" | 24" | 24" | 24" | 21" | 21" | 21" | 18" | 18" | 18" | 18" | |
| | | | 64" | 64" | 64" | 24" | 24" | 24" | 24" | 24" | 21" | 21" | 21" | 18" | 18" | 18" | 18" | 18" |
| | | | 72" | 72" | 72" | 24" | 24" | 24" | 24" | 24" | 21" | 21" | 21" | 18" | 18" | 18" | 18" | 18" |
| 100 mph | 130 mph | 7:12 to 6:12 | 72" | 72" | 72" | 24" | 24" | 24" | 24" | 24" | 21" | 21" | 21" | 18" | 18" | 18" | 18" | |
| | | | 64" | 64" | 64" | 24" | 24" | 24" | 24" | 24" | 21" | 21" | 21" | 18" | 18" | 18" | 18" | 18" |
| | | | 72" | 72" | 72" | 24" | 24" | 24" | 24" | 24" | 21" | 21" | 21" | 18" | 18" | 18" | 18" | 18" |
| 110 mph | 140 mph | 7:12 to 6:12 | 72" | 72" | 72" | 24" | 24" | 24" | 24" | 24" | 21" | 21" | 21" | 18" | 18" | 18" | 18" | |
| | | | 64" | 64" | 64" | 24" | 24" | 24" | 24" | 24" | 21" | 21" | 21" | 18" | 18" | 18" | 18" | 18" |
| | | | 72" | 72" | 72" | 24" | 24" | 24" | 24" | 24" | 21" | 21" | 21" | 18" | 18" | 18" | 18" | 18" |
| 120 mph | 150 mph | 7:12 to 6:12 | 64" | 64" | 64" | 24" | 24" | 24" | 24" | 24" | 21" | 21" | 21" | 18" | 18" | 18" | 18" | |
| | | | 48" | 48" | 48" | 22" | 22" | 22" | 22" | 22" | 18" | 18" | 18" | 15" | 15" | 15" | 15" | 15" |
| | | | 48" | 48" | 48" | 22" | 22" | 22" | 22" | 22" | 18" | 18" | 18" | 15" | 15" | 15" | 15" | 15" |

Table Notes:

- The Quick Rack base mount maximum cantilever listed in this table is the distance from center of clamp bolt (in top slider) to end of module (see Figure 4).
- The "backspan" is the first span (i.e. mount spacing) inward from the cantilever (see Figure 4). In this table (Table 1B), backspan matches typical span from Table 1A.
- See Table 1C, notes 3 through 9, which also apply to this table.

Table 1C. Quick Rack Base Mount Maximum East and West Cantilevers, Modules in **Landscapes** Orientation with Atypical 16" or 24" Backspan

| Wind Speed (Service Level) | ASCE 7-10 (Strength Level) | Roof Pitch | Typical Span (see Table 1A) | | | | | | Maximum Mount Cantilever with Atypical Backspan = 16" or 24" | | | | | | | | | | |
|-------------------------------|-------------------------------|--------------|--------------------------------|-----|-----|--------------------------|------------------------|-----|--|-----|------------------------|--------------------------|-----|-----|------------------------|-----|-----|-----|-----|
| | | | Roof Edge Distance = 36"+ | | | Roof Edge Distance = 24" | | | Roof Edge Distance = 18" | | | Roof Edge Distance = 12" | | | | | | | |
| | | | Wind Exposure Category | B | C | D | Wind Exposure Category | B | C | D | Wind Exposure Category | B | C | D | Wind Exposure Category | B | C | D | |
| 85 mph | 110 mph | 7:12 to 6:12 | 72" | 72" | 72" | 24" | 24" | 24" | 24" | 24" | 24" | 24" | 24" | 24" | 24" | 24" | 24" | 24" | |
| | | | 64" | 64" | 64" | 24" | 24" | 24" | 24" | 24" | 24" | 24" | 24" | 24" | 24" | 24" | 24" | 24" | 24" |
| | | | 72" | 72" | 72" | 24" | 24" | 24" | 24" | 24" | 24" | 24" | 24" | 24" | 24" | 24" | 24" | 24" | 24" |
| 90 mph | 115 mph | 7:12 to 6:12 | 72" | 72" | 72" | 24" | 24" | 24" | 24" | 24" | 24" | 24" | 24" | 24" | 24" | 24" | 24" | 24" | |
| | | | 64" | 64" | 64" | 24" | 24" | 24" | 24" | 24" | 24" | 24" | 24" | 24" | 24" | 24" | 24" | 24" | 24" |
| | | | 72" | 72" | 72" | 24" | 24" | 24" | 24" | 24" | 24" | 24" | 24" | 24" | 24" | 24" | 24" | 24" | 24" |
| 95 mph | 120 mph | 7:12 to 6:12 | 72" | 72" | 72" | 24" | 24" | 24" | 24" | 24" | 24" | 24" | 24" | 24" | 24" | 24" | 24" | 24" | |
| | | | 64" | 64" | 64" | 24" | 24" | 24" | 24" | 24" | 24" | 24" | 24" | 24" | 24" | 24" | 24" | 24" | 24" |
| | | | 72" | 72" | 72" | 24" | 24" | 24" | 24" | 24" | 24" | 24" | 24" | 24" | 24" | 24" | 24" | 24" | 24" |
| 100 mph | 130 mph | 7:12 to 6:12 | 64" | 64" | 64" | 24" | 24" | 24" | 24" | 24" | 24" | 24" | 24" | 24" | 24" | 24" | 24" | 24" | |
| | | | 48" | 48" | 48" | 24" | 24" | 24" | 24" | 24" | 24" | 24" | 24" | 24" | 24" | 24" | 24" | 24" | 24" |
| | | | 48" | 48" | 48" | 24" | 24" | 24" | 24" | 24" | 24" | 24" | 24" | 24" | 24" | 24" | 24" | 24" | 24" |
| 110 mph | 140 mph | 7:12 to 6:12 | 72" | 72" | 72" | 24" | 24" | 24" | 24" | 24" | 24" | 24" | 24" | 24" | 24" | 24" | 24" | 24" | |
| | | | 64" | 64" | 64" | 24" | 24" | 24" | 24" | 24" | 24" | 24" | 24" | 24" | 24" | 24" | 24" | 24" | 24" |
| | | | 48" | 48" | 48" | 24" | 24" | 24" | 24" | 24" | 24" | 24" | 24" | 24" | 24" | 24" | 24" | 24" | 24" |
| 120 mph | 150 mph | 7:12 to 6:12 | 64" | 64" | 64" | 24" | 24" | 24" | 24" | 24" | 24" | 24" | 24" | 24" | 24" | 24" | 24" | 24" | |
| | | | 48" | 48" | 48" | 24" | 24" | 24" | 24" | 24" | 24" | 24" | 24" | 24" | 24" | 24" | 24" | 24" | 24" |
| | | | 48" | 48" | 48" | 24" | 24" | 24" | 24" | 24" | 24" | 24" | 24" | 24" | 24" | 24" | 24" | 24" | 24" |

Table Notes:

- The Quick Rack base mount maximum cantilever listed in this table is the distance from center of clamp bolt (in top slider) to end of module (see Figure 4).
- The "backspan" is the first span (i.e. mount spacing) inward from the cantilever (see Figure 4). In this table (Table 1C), backspan is one rafter spacing (16" or 24").
- The "module cantilever" is measured from end of module to closest edge of clamp (see Figure 4). Installer shall verify that module cantilever does not exceed manufacturer recommendations.
- The "roof edge distance" is the lateral cross-slope distance from gable end, rake, hip or other roof edge, to end of perimeter module (see Figure 4).
- + For buildings with the narrow side wider than 30 feet, increase 36" to 10% of building least plan (footprint) dimension.
- This table is based on an assumed PV module size no larger than 40" x 66".
- High snow load regions: above 20 psf ground snow load, the maximum mount cantilever shall be the lesser of:
(i) the maximum cantilever shown in Tables 1B or 1C above, or (ii) half the maximum mount spacing shown in Table 1A (see previous page).
- The maximum allowable cantilever shown in these tables ensure that the end mounts & rafters under the array are loaded no more heavily than the interior ones.

Table 2A. Quick Rack Base Mount Maximum Spacing, Modules in **Portrait** Orientation

| Wind Speed (Service Level) | ASCE 7-10 (Strength Level) | Roof Pitch | Ground Snow Load | | | | | | | | | | | | | | | | | | | | | | | | |
|-------------------------------|-------------------------------|---------------|------------------|---------|---------------|---------|-------------|---------------|-----|-----|-------------|-----|-----|-----|-----|-----|-----|-----|-----|-----|-----|-----|-----|-----|-----|-----|-----|
| | | | 0 - 15 psf | | | | 16 - 30 psf | | | | 31 - 45 psf | | | | | | | | | | | | | | | | |
| | | | B | C | D | B | C | D | B | C | D | B | C | D | | | | | | | | | | | | | |
| 85 mph | 110 mph | 2:12 to 6:12 | 48" | 48" | 32" | 48" | 48" | 32" | 48" | 48" | 32" | 48" | 48" | 32" | 48" | 48" | 32" | 48" | 48" | 32" | 48" | 48" | 32" | | | | |
| | | | 90 mph | 115 mph | 7:12 to 12:12 | 48" | 48" | 32" | 48" | 48" | 32" | 48" | 48" | 32" | 48" | 48" | 32" | 48" | 48" | 32" | 48" | 48" | 32" | 48" | 48" | 32" | |
| | | | | | | 95 mph | 120 mph | 2:12 to 6:12 | 48" | 48" | 32" | 48" | 48" | 32" | 48" | 48" | 32" | 48" | 48" | 32" | 48" | 48" | 32" | 48" | 48" | 32" | 48" |
| 100 mph | 130 mph | 7:12 to 12:12 | 32" | 32" | 24" | | | | 32" | 32" | 24" | 32" | 32" | 24" | 32" | 32" | 24" | 32" | 32" | 24" | 32" | 32" | 24" | 32" | 32" | 24" | 32" |
| | | | 110 mph | 140 mph | 2:12 to 6:12 | 48" | 48" | 32" | 48" | 48" | 32" | 48" | 48" | 32" | 48" | 48" | 32" | 48" | 48" | 32" | 48" | 48" | 32" | 48" | 48" | 32" | 48" |
| | | | | | | 120 mph | 150 mph | 7:12 to 12:12 | 32" | 32" | 24" | 32" | 32" | 24" | 32" | 32" | 24" | 32" | 32" | 24" | 32" | 32" | 24" | 32" | 32" | 24" | 32" |
| 120 mph | 150 mph | 7:12 to 12:12 | 32" | 32" | 24" | | | | 32" | 32" | 24" | 32" | 32" | 24" | 32" | 32" | 24" | 32" | 32" | 24" | 32" | 32" | 24" | 32" | 32" | 24" | 32" |

Table Notes:

1. The Quick Rack base mount maximum allowable spacing listed in this table is the spacing between base mount attachment points in the roof cross-slope direction for modules in portrait orientation.
2. This table is based on an assumed PV module size no larger than 40" x 66".
3. See Figure 4 and Tables 2B and 2C for the maximum mount cantilever (clamp bolt to end-of-module) at the nominal east or west edge of array (cross-slope edge of roof).
4. This table is subject to the conditions stated in the attached Code Compliance Letter, and shown in the attached sketches.
5. This table is based on ASCE 7-10. ASCE 7-05 wind speeds are back-calculated from ASCE 7-10 wind speeds to produce the same wind pressures, rounded to nearest 5 mph.
6. Wind load calculations are based on a Risk Category II building with a mean roof height of 35 feet and $I_w = 1.0$.
7. Snow load calculations are based on $C_e = 1.0$, $I_s = 1.0$, $C_t = 1.2$ and ASCE 7-10 Fig.7-2a for unobstructed slippery surface (ref. ASCE 7-10 Commentary C7.8)
8. See Table 3 for regions of high wind or snow load where a staggered base mount layout is recommended.
9. The roof pitch range "2:12 to 6:12" corresponds to 9 to 27 degree roof slopes; the roof pitch range "7:12 to 12:12" corresponds to 27.1 to 45 degree roof slopes.
10. Mount capacities are based on ICC AC-13, and are not increased for load duration factor per the restrictions of AC-13. See Appendix 1 for additional information.
11. For locations with an unusual combination of both high seismic and snow loads, see Appendix 2, Table A2.2.

Table 2B. Quick Rack Base Mount Maximum East and West Cantilevers, Modules in **Portrait** Orientation with Typical Backspan from Table 2A

| Wind Speed ASCE 7-10 (Service) (Strength) | Typical Span (see Table 2A) | | | | Maximum Mount Cantilever with Backspan = Typical Span | | | | | | | | | | | | | | | |
|--|--------------------------------|-----|-----|--------------|---|-----|-----|------------------------|--------------------------|-----|-----|------------------------|--------------------------|----|----|------------------------|--------------------------|----|----|------------------------|
| | Wind Exposure Category | | | | Roof Edge Distance = 36"+ | | | | Roof Edge Distance = 24" | | | | Roof Edge Distance = 18" | | | | Roof Edge Distance = 12" | | | |
| | B | C | D | Roof Pitch | B | C | D | Wind Exposure Category | B | C | D | Wind Exposure Category | B | C | D | Wind Exposure Category | B | C | D | Wind Exposure Category |
| 85 mph | 48" | 32" | 48" | 2:12 to 6:12 | 22" | 22" | 15" | 14" | 14" | 14" | 7" | 12" | 12" | 6" | 6" | 9" | 9" | 4" | 4" | 4" |
| 90 mph | 48" | 32" | 48" | 2:12 to 6:12 | 22" | 22" | 15" | 14" | 14" | 7" | 12" | 12" | 6" | 6" | 9" | 9" | 4" | 4" | 4" | 4" |
| 95 mph | 48" | 32" | 48" | 2:12 to 6:12 | 22" | 22" | 15" | 14" | 14" | 7" | 12" | 12" | 6" | 6" | 9" | 9" | 4" | 4" | 4" | 4" |
| 100 mph | 48" | 32" | 48" | 2:12 to 6:12 | 22" | 22" | 15" | 14" | 14" | 7" | 12" | 12" | 6" | 6" | 9" | 9" | 4" | 4" | 4" | 4" |
| 110 mph | 32" | 24" | 32" | 2:12 to 6:12 | 15" | 15" | 12" | 7" | 7" | 4" | 4" | 6" | 6" | 4" | 4" | 4" | 4" | 4" | 4" | 3" |
| 120 mph | 32" | 24" | 32" | 2:12 to 6:12 | 15" | 15" | 12" | 7" | 7" | 4" | 4" | 6" | 6" | 4" | 4" | 4" | 4" | 4" | 4" | 3" |

Table Notes:

1. The Quick Rack base mount maximum cantilever listed in this table is the distance from center of clamp bolt (in top slider) to end of module (see Figure 4).
2. The "backspan" is the first span (i.e. mount spacing) inward from the cantilever (see Figure 4). In this table (Table 2B), backspan matches typical span from Table 2A.
3. See Table 2C, notes 3 through 9, which also apply to this table.

Table 2C. Quick Rack Base Mount Maximum East and West Cantilevers, Modules in **Portrait** Orientation with Atypical Backspan = 16" or 24" Backspan

| Wind Speed ASCE 7-10 (Service) (Strength) | Typical Span (see Table 2A) | | | | Maximum Mount Cantilever with Atypical Backspan = 16" or 24" | | | | | | | | | | | | | | | |
|--|--------------------------------|-----|-----|--------------|--|-----|-----|------------------------|--------------------------|-----|-----|------------------------|--------------------------|-----|-----|------------------------|--------------------------|----|----|------------------------|
| | Wind Exposure Category | | | | Roof Edge Distance = 36"+ | | | | Roof Edge Distance = 24" | | | | Roof Edge Distance = 18" | | | | Roof Edge Distance = 12" | | | |
| | B | C | D | Roof Pitch | B | C | D | Wind Exposure Category | B | C | D | Wind Exposure Category | B | C | D | Wind Exposure Category | B | C | D | Wind Exposure Category |
| 85 mph | 48" | 32" | 48" | 2:12 to 6:12 | 24" | 24" | 17" | 16" | 16" | 16" | 11" | 11" | 15" | 15" | 10" | 13" | 13" | 9" | 9" | 9" |
| 90 mph | 48" | 32" | 48" | 2:12 to 6:12 | 24" | 24" | 17" | 16" | 16" | 16" | 11" | 11" | 15" | 15" | 10" | 13" | 13" | 9" | 9" | 9" |
| 95 mph | 48" | 32" | 48" | 2:12 to 6:12 | 24" | 24" | 17" | 16" | 16" | 16" | 11" | 11" | 15" | 15" | 10" | 13" | 13" | 9" | 9" | 9" |
| 100 mph | 48" | 32" | 48" | 2:12 to 6:12 | 24" | 24" | 17" | 16" | 16" | 16" | 11" | 11" | 15" | 15" | 10" | 13" | 13" | 9" | 9" | 9" |
| 110 mph | 32" | 24" | 32" | 2:12 to 6:12 | 17" | 17" | 12" | 11" | 11" | 4" | 4" | 10" | 10" | 4" | 4" | 9" | 9" | 3" | 3" | 3" |
| 120 mph | 32" | 24" | 32" | 2:12 to 6:12 | 17" | 17" | 12" | 11" | 11" | 4" | 4" | 10" | 10" | 4" | 4" | 9" | 9" | 3" | 3" | 3" |

Table Notes:

1. The Quick Rack base mount maximum cantilever listed in this table is the distance from center of clamp bolt (in top slider) to end of module (see Figure 4).
2. The "backspan" is the first span (i.e. mount spacing) inward from the cantilever (see Figure 4). In this table (Table 2C), backspan is one rafter spacing (16" or 24").
3. The "module cantilever" is measured from end of module to closest edge of clamp (see Figure 4). Installer shall verify that module cantilever does not exceed manufacturer recommendations.
4. The "roof edge distance" is the lateral cross-slope distance from gable end, rake, hip or other roof edge, to end of perimeter module (see Figure 4).
5. + For buildings with the narrow side wider than 30 feet, increase 36" to 10% of building least plan (footprint) dimension
6. This table is based on an assumed PV module size no larger than 40"x66".
7. High snow load regions: above 15 psf ground snow load, the maximum mount cantilever shall be the lesser of:
(i) the maximum cantilever shown in Tables 2B or 2C above, or (ii) half the maximum mount spacing shown in Table 2A (see previous page).
8. The maximum allowable cantilever shown in these tables ensure that the end mounts & rafters under the array are loaded no more heavily than the interior ones.

Table 3. Rectangular versus Staggered Anchor Patterns (Mount Layouts)

| | | Wind Exposure Category | | | | | | | | | | | |
|------------------|----------------------|---|-------|-------|-------|-------|-------|-------|-------|-------|-------|-------|-------|
| | | B | | | | C | | | | D | | | |
| Ground Snow Load | ASCE 7-10 Wind Speed | Quick Rack Base Mount Spacing, n = # of Rafter Spaces | | | | | | | | | | | |
| | | n = 1 | n = 2 | n = 3 | n = 4 | n = 1 | n = 2 | n = 3 | n = 4 | n = 1 | n = 2 | n = 3 | n = 4 |
| | Roof Pitch | n = 1 | n = 2 | n = 3 | n = 4 | n = 1 | n = 2 | n = 3 | n = 4 | n = 1 | n = 2 | n = 3 | n = 4 |
| 0 psf | 110 mph | Flat to 6:12 | RAP | RAP | RAP | RAP | RAP | RAP | RAP | RAP | RAP | RAP | RAP |
| | | 7:12 to 12:12 | RAP | SA | SA* | SA** | RAP | SA | SA** | RAP | SA | SA** | RAP |
| | 115 mph | Flat to 6:12 | RAP | RAP | RAP | RAP | RAP | RAP | RAP | RAP | RAP | RAP | RAP |
| | | 7:12 to 12:12 | RAP | SA | SA* | SA** | RAP | SA | SA** | RAP | SA | SA** | RAP |
| 1 - 10 psf | 130 mph | Flat to 6:12 | RAP | SA | SA* | SA** | RAP | SA | SA** | RAP | SA | SA** | RAP |
| | | 7:12 to 12:12 | RAP | RAP | RAP | RAP | RAP | RAP | RAP | RAP | RAP | RAP | RAP |
| | 140 mph | Flat to 6:12 | RAP | SA | SA* | SA** | RAP | SA | SA** | RAP | SA | SA** | RAP |
| | | 7:12 to 12:12 | RAP | RAP | RAP | RAP | RAP | RAP | RAP | RAP | RAP | RAP | RAP |
| > 10 psf | 150 mph | Flat to 6:12 | RAP | SA | SA* | SA** | RAP | SA | SA** | RAP | SA | SA** | RAP |
| | | 7:12 to 12:12 | RAP | RAP | RAP | RAP | RAP | RAP | RAP | RAP | RAP | RAP | RAP |
| | 110 mph | Flat to 6:12 | RAP | SA | SA* | SA** | RAP | SA | SA** | RAP | SA | SA** | RAP |
| | | 7:12 to 12:12 | RAP | RAP | RAP | RAP | RAP | RAP | RAP | RAP | RAP | RAP | RAP |
| | 115 mph | Flat to 6:12 | RAP | SA | SA* | SA** | RAP | SA | SA** | RAP | SA | SA** | RAP |
| | | 7:12 to 12:12 | RAP | RAP | RAP | RAP | RAP | RAP | RAP | RAP | RAP | RAP | RAP |
| | 130 mph | Flat to 6:12 | RAP | SA | SA* | SA** | RAP | SA | SA** | RAP | SA | SA** | RAP |
| | | 7:12 to 12:12 | RAP | RAP | RAP | RAP | RAP | RAP | RAP | RAP | RAP | RAP | RAP |
| | 140 mph | Flat to 6:12 | RAP | SA | SA* | SA** | RAP | SA | SA** | RAP | SA | SA** | RAP |
| | | 7:12 to 12:12 | RAP | RAP | RAP | RAP | RAP | RAP | RAP | RAP | RAP | RAP | RAP |
| | 150 mph | Flat to 6:12 | RAP | SA | SA* | SA** | RAP | SA | SA** | RAP | SA | SA** | RAP |
| | | 7:12 to 12:12 | RAP | RAP | RAP | RAP | RAP | RAP | RAP | RAP | RAP | RAP | RAP |
| | 110 mph | Flat to 6:12 | RAP | SA | SA* | SA** | RAP | SA | SA** | RAP | SA | SA** | RAP |
| | | 7:12 to 12:12 | RAP | RAP | RAP | RAP | RAP | RAP | RAP | RAP | RAP | RAP | RAP |
| | 115 mph | Flat to 6:12 | RAP | SA | SA* | SA** | RAP | SA | SA** | RAP | SA | SA** | RAP |
| | | 7:12 to 12:12 | RAP | RAP | RAP | RAP | RAP | RAP | RAP | RAP | RAP | RAP | RAP |
| | 130 mph | Flat to 6:12 | RAP | SA | SA* | SA** | RAP | SA | SA** | RAP | SA | SA** | RAP |
| | | 7:12 to 12:12 | RAP | RAP | RAP | RAP | RAP | RAP | RAP | RAP | RAP | RAP | RAP |
| | 140 mph | Flat to 6:12 | RAP | SA | SA* | SA** | RAP | SA | SA** | RAP | SA | SA** | RAP |
| | | 7:12 to 12:12 | RAP | RAP | RAP | RAP | RAP | RAP | RAP | RAP | RAP | RAP | RAP |
| | 150 mph | Flat to 6:12 | RAP | SA | SA* | SA** | RAP | SA | SA** | RAP | SA | SA** | RAP |
| | | 7:12 to 12:12 | RAP | RAP | RAP | RAP | RAP | RAP | RAP | RAP | RAP | RAP | RAP |

Table Notes:

RAP = Rectangular Anchor Pattern. If the installer verifies the existing roof is code compliant without the array, it is likely to have sufficient strength to support a PV array without staggering base mounts.
 SA = Stagger Anchors. Alternatively, Structurally Assess and Strengthen as Appropriate. See Figures 7 - 10 for acceptable staggered base mount layouts.

* The staggered pattern shown in Figure 8 is NOT acceptable. Instead, reduce the base mount spacing and use the staggered pattern shown in Figure 9.

** The staggered pattern shown in Figure 7 is NOT acceptable. Instead, reduce the base mount spacing and use the staggered pattern shown in Figure 9.

1. This table provides general guidelines for when a base mount layout that is anchored to every second, third or fourth rafter is likely to be acceptable when installed in a **rectangular** pattern, and when a **staggered** base mount layout (or alternatively, a structural engineering assessment) is required instead.

2. The installer is responsible for verifying that the existing roof can support typical code-required roof loads by:

(a) checking existing roof rafter spans against the roof rafter span tables of the 2012 International Building Code (Table 2308.10.3(1)), the 2012 International Residential Code (Table R805.2.1(1)), or similar superseding state code (available at: <https://law.resource.org/pub/us/code/safety.html>). If lumber grade stamps are not visible,

some engineers consider it reasonable to assume Douglas Fir No. 2 in states west of the Rocky Mountains (CA, OR, WA, NV, ID) and Spruce-Pine-Fir No. 2 in the remainder of the continental United States, and

(b) verifying the existing roof structure is free of damage, decay or unusual sagging. Refer to Figure 1 of Toolkit Document #5 (Structural Criteria for Residential Rooftop Solar Energy Installations) on page 53 of the *2015 California Solar Permitting Guidebook* (available at: <https://energycenter.org/permitting/guidebook> or <http://www.opr.ca.gov/docs/>).

3. Concentrated loads on a rafter from Quick Rack base mounts are assumed to be partially shared with adjacent rafters as described in Section 2.F of the *Structural Technical Appendix for Residential Rooftop Solar Installations* (available at: http://www.opr.ca.gov/docs/Solar_Structural_Technical_Appendix.pdf),

4. The roof pitch range "2:12 to 6:12" corresponds to 9 to 27 degree roof slopes; the roof pitch range "7:12 to 12:12" corresponds to 27.1 to 45 degree roof slopes.

5. This table does not apply to wood trusses. Consult with a structural engineer or the original truss manufacturer to verify that existing trusses can carry the specific loading pattern of a new solar array.

Clamp and Top Slider Allowable Positions Figure 2B

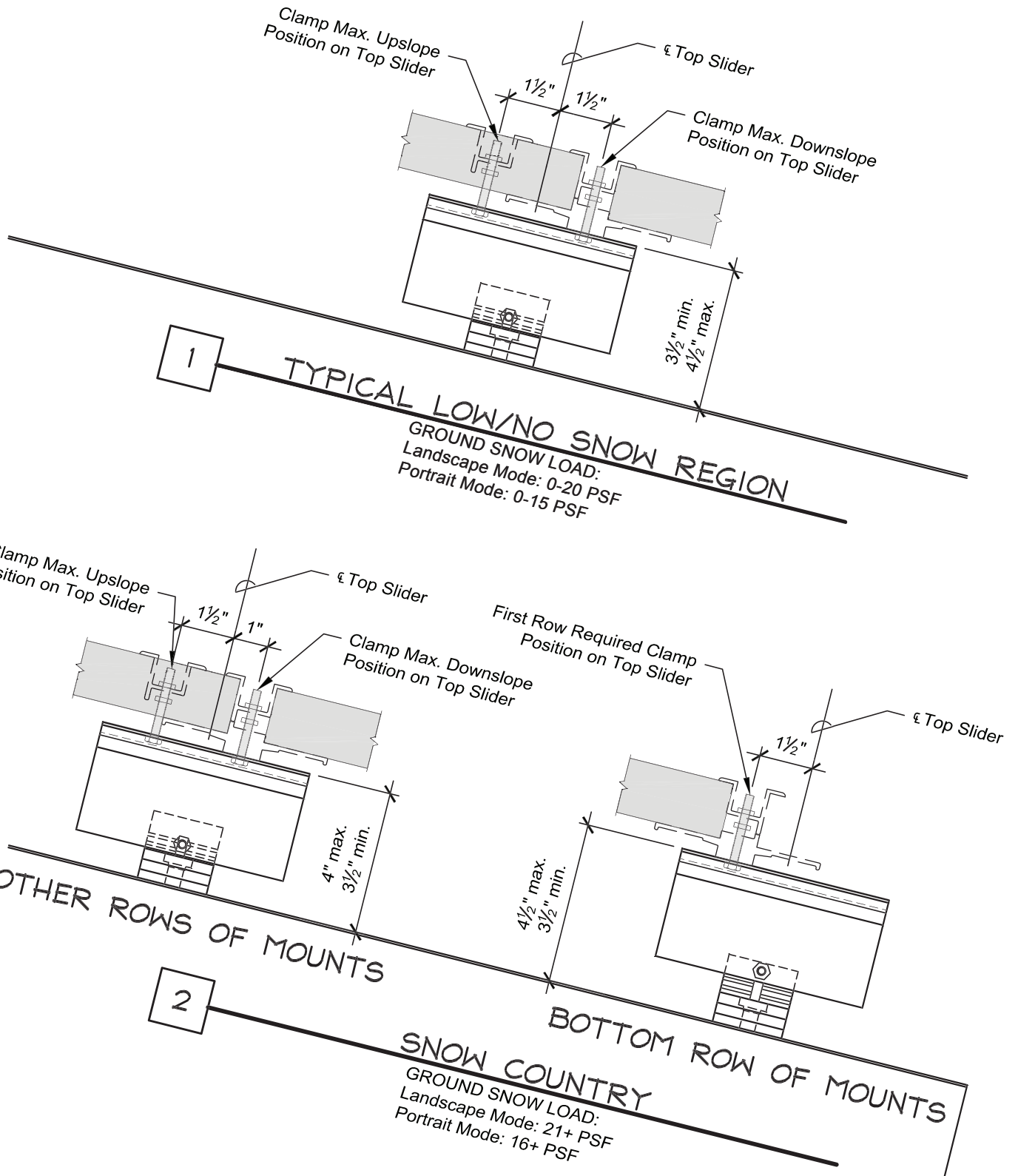

Cantilever Reference Figure 4

This figure references tables on pages **Ref-3 - Ref-7**.

Reference

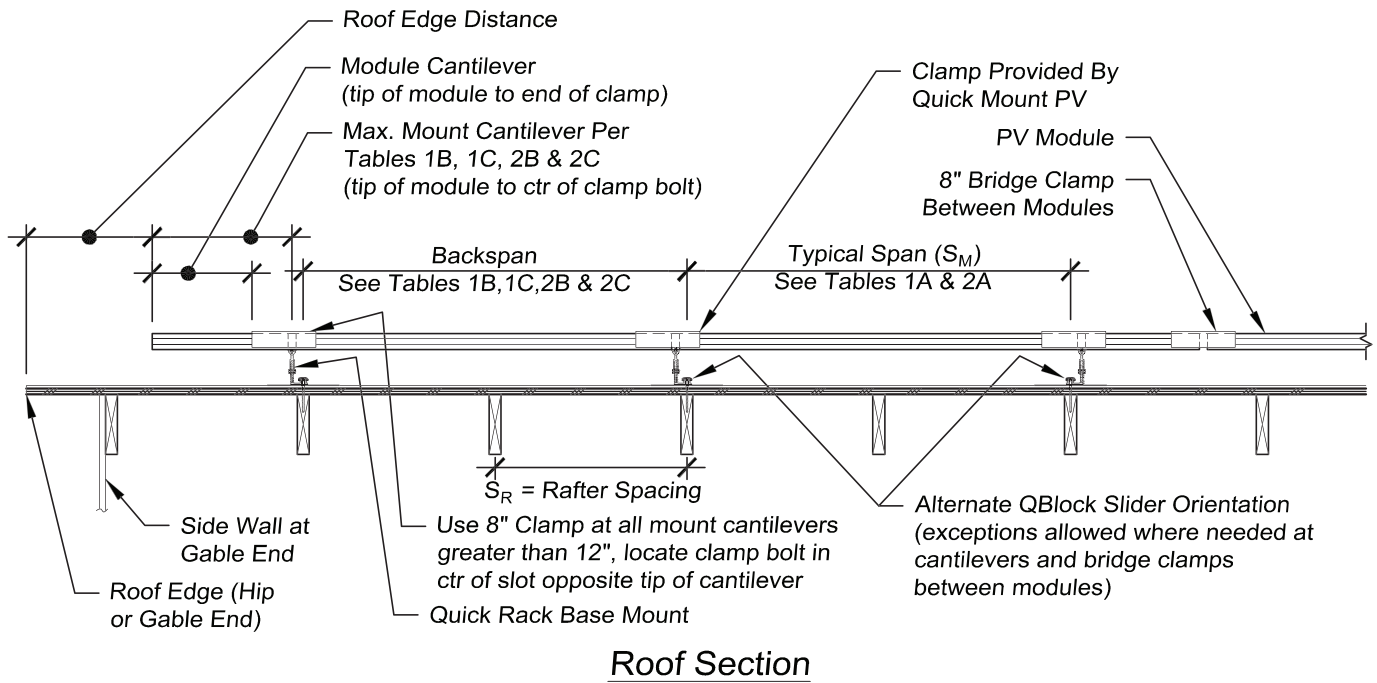

Rafter Attachment Pattern Figure 7

S_M = Base Mount Spacing
 S_R = Rafter Spacing
 n = Number Of Rafter Spaces
 $= S_M / S_R$

$n = 4$ Rafter Attachment Pattern

For $S_R = 16"$ o.c.

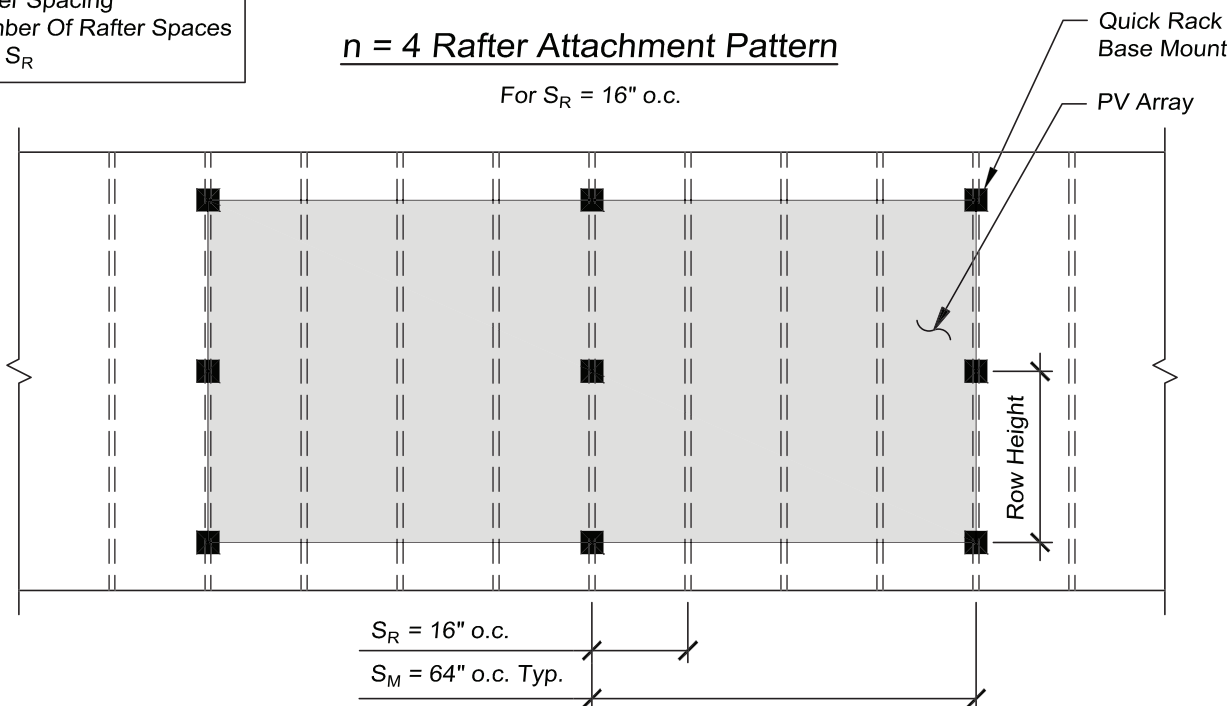

Staggered Rafter Attachment Pattern To Attain $n = 2$ Equivalence

For $S_R = 16"$ o.c.

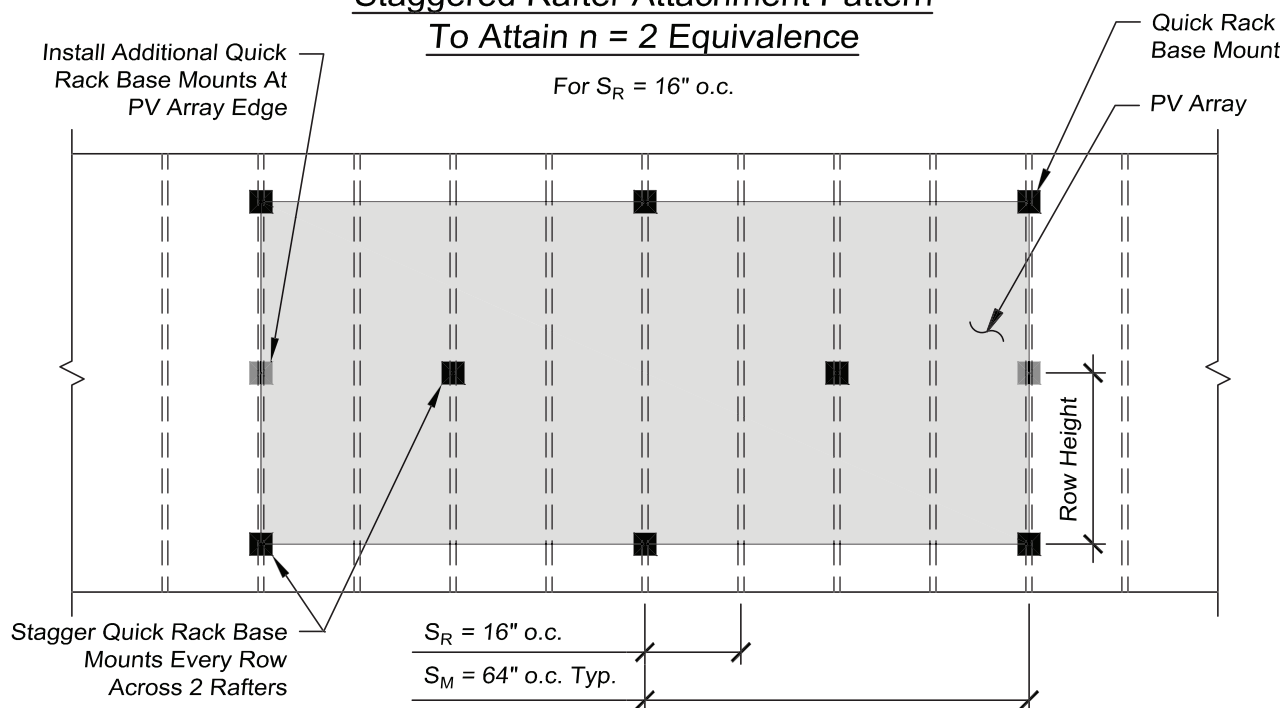

Note: This staggered pattern is NOT acceptable where SA** is indicated for $n=4$ in Table 3. Instead, reduce the base mount spacing to 32" and stagger per Figure 9.

Rafter Attachment Pattern Figure 8

S_M = Base Mount Spacing
 S_R = Rafter Spacing
 n = Number Of Rafter Spaces
 $= S_M / S_R$

$n = 3$ Rafter Attachment Pattern

For $S_R = 16"$ o.c. & $24"$ o.c.

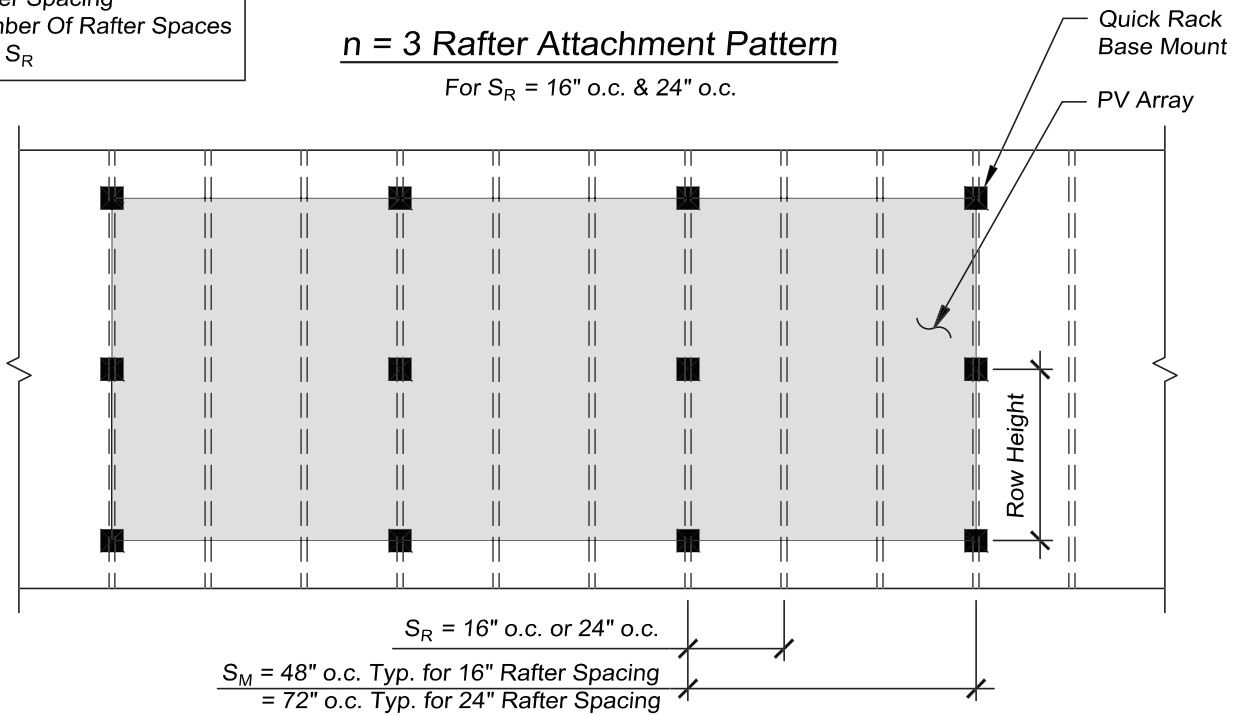

Staggered Rafter Attachment Pattern To Attain $n = 2$ Equivalence

For $S_R = 16"$ o.c. & $24"$ o.c.

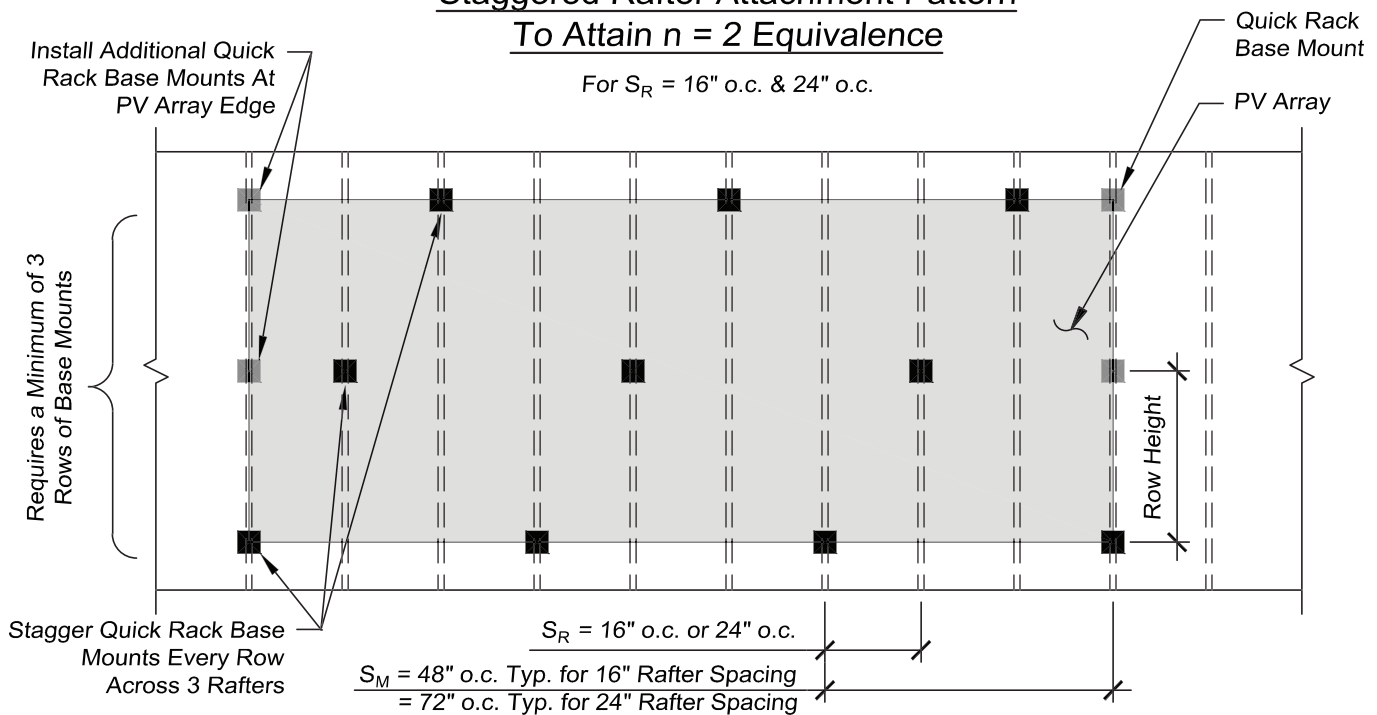

Note: This staggered pattern is NOT acceptable where SA* is indicated for $n=3$ or SA** is indicated for $n=4$ in Table 3. Instead, reduce the base mount spacing and stagger per Figure 9.

Rafter Attachment Pattern Figure 9

S_M = Base Mount Spacing
 S_R = Rafter Spacing
 n = Number Of Rafter Spaces
 $= S_M / S_R$

$n = 2$ Rafter Attachment Pattern

For $S_R = 16"$ o.c. & $24"$ o.c.

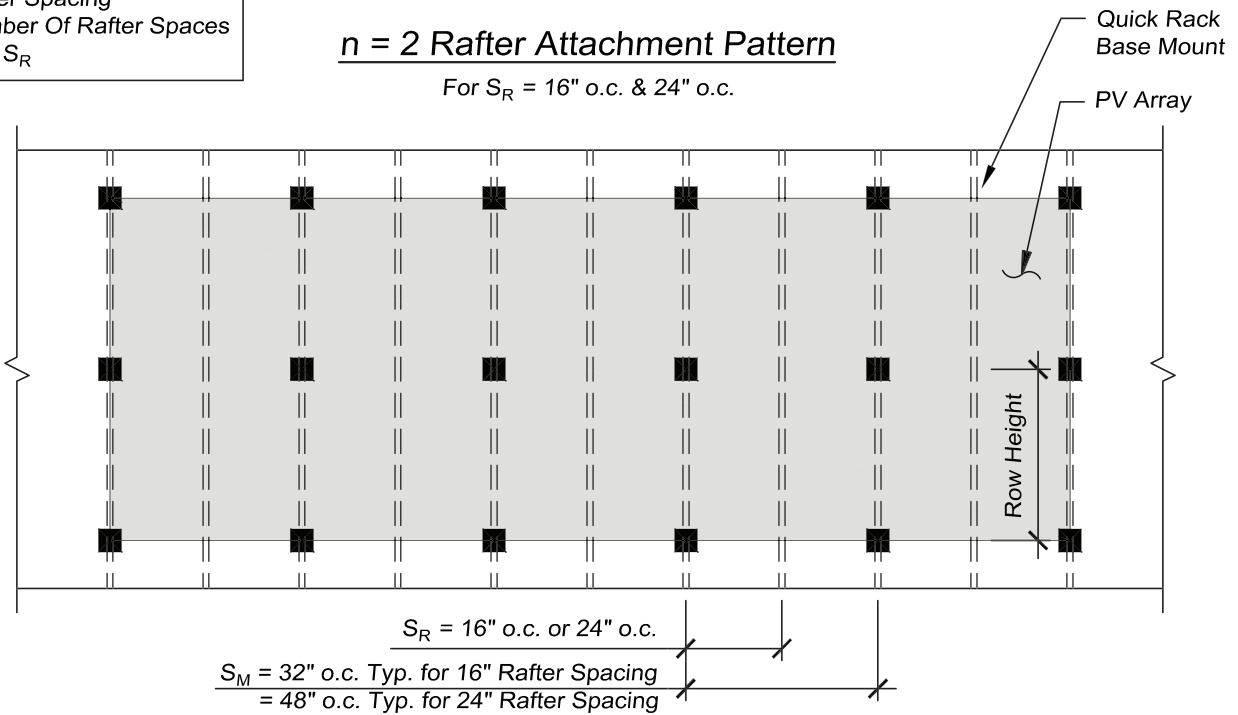

Staggered Rafter Attachment Pattern To Attain $n = 1$ Equivalence

For $S_R = 16"$ o.c. & $24"$ o.c.

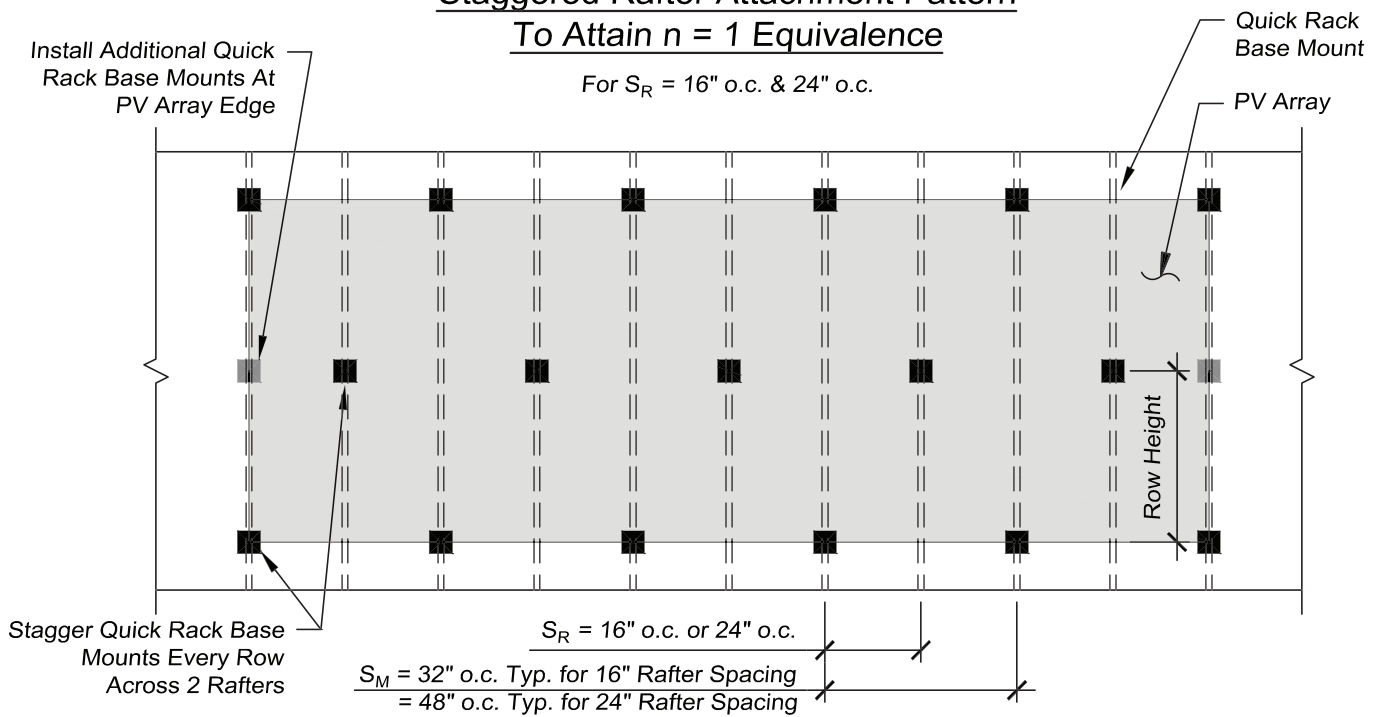

Rafter Attachment Pattern Figure 10

S_M = Base Mount Spacing
 S_R = Rafter Spacing
 n = Number Of Rafter Spaces
= S_M / S_R

$n = 1$ Rafter Attachment Pattern

For $S_R = 16''$ o.c. & $24''$ o.c.

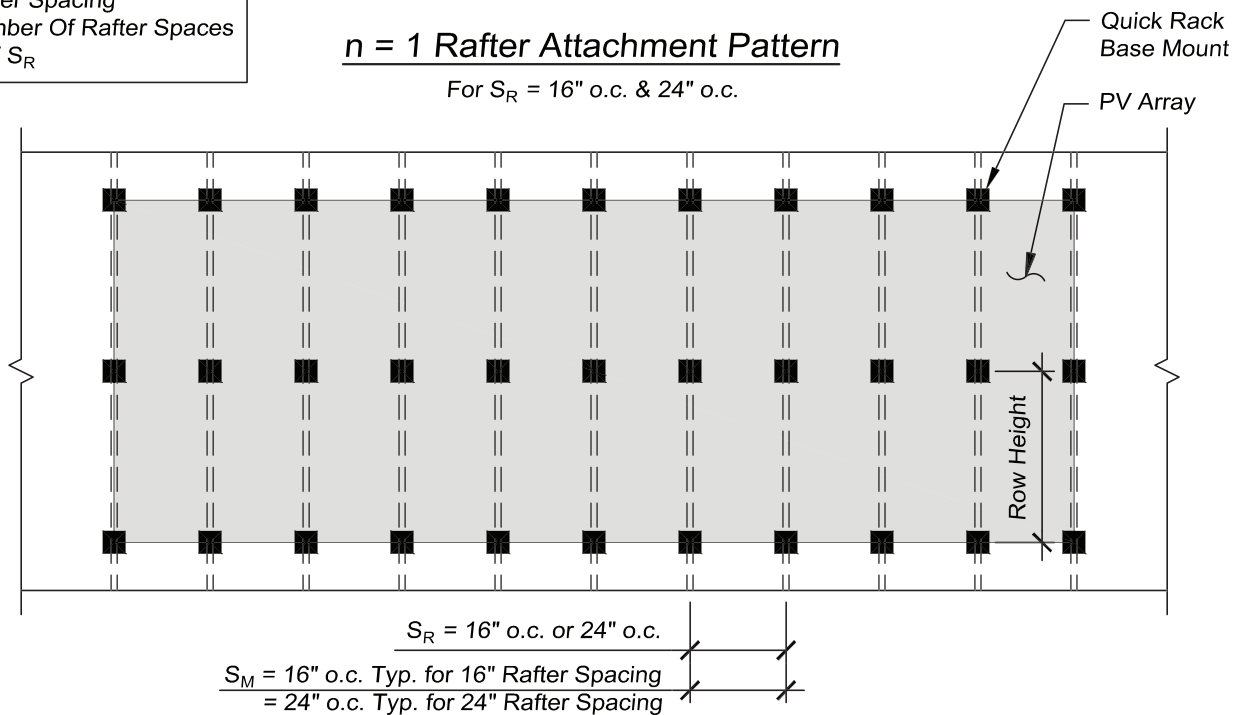

C. Code Compliance

- 2009 International Building Code compliant
- 2013 California Building Code compliant
- ASCE 7-05 Minimum Design Loads for Buildings and Other Structures compliant
- ASCE 7-10 Minimum Design Loads for Buildings and Other Structures compliant
- Conforms to UL SUB 2703, ETL listed by Intertek, see page **Ref-15** for compliance requirements.

D. UL2703 Compliance Requirements

Evaluated and Approved Modules for use with Quick Rack

| Approved Modules |
|---|
| BenQ Green Triplex |
| PM060M02-XXX, PM060P00-XXX, PM245P00-XXX, PM250M01-XXX, PM245P03-XXX |
| ET Solar |
| ET-P660BB, ET-P660WB, ET-P660WW, ET-M660BB, ET-M660WW, ET-P660XXXWWG |
| LG Solar Mono X |
| LGXXS1C-G3, LGXXS1C-A3, LGXXS1C-B3, LGXXS1K-G3, LGXXS1K-A3, LGXXS1K-B3 |
| LG Solar Mono X NeON |
| LGXXN1C-G3, LGXXN1C-A3, LGXXN1C-B3 |
| Trina Solar |
| TSM-XXX-PA05.05, TSM-XXX-PA05.08, TSM-XXX-PD05.05, TSM-XXX-PD05.08 |
| Yingli Solar YGE 60 Cell |
| YLXXP-29b 40mm, YLXXP-29b 35mm |
| Suniva Optimus & MV Series |
| Black OPT XXX-60-4-1B0, Silver OPT XXX-60-4-100, MVX XXX-60-5-100 |
| Hanwha Solar HSL 60 & HSL 72 |
| HSL60P6-PB-0-XXXT, HSL60P6-PB-0-XXXTW, HSL60P6-PB-0-XXXTB, HSL60P6-PB-4-XXXT, HSL60P6-PB-4-XXXTW, HSL60P6-PB-4-XXXTB, HSL60P6-PB-1-XXX, HSL60P6-PB-1-XXXB |
| Canadian Solar |
| CS6P-XXXP, CS6P-XXXM, CS6P-XXXM All Black |
| Renesola 156 Series |
| JCXXS-24/Bb, JCXXF-24/Bb-b, JCXXS-24/Bb-b |
| Renesola Clarus, Virtus, & Virtus II |
| JCXXM-24/Bb, JXXM-24/Bbv, JCXXM-24/Bb, JCXXM-24/Bbh |

Approved Modules Cont'd**Hyundai Solar MF-Series & MG Series**

HiS-SXXXMF, HiS-MXXXMG, HiS-SXXXMG

SolarWorld Sun Module Pro Poly & Plus Mono

SWXXX POLY, SWXXX-MONO, SWXXX-MONO BLACK

Note: Module wattage is represented by XXX in product codes.

Grounding Information

The Quick Rack rail-free mounting system may be used to ground and mount the PV module complying with UL 1703 only when the specific module has been evaluated for grounding and mounting in compliance with the included instructions.

Grounding lug must be visible to inspectors from the perimeter of the array.

To avoid breaking or disturbing the bonding path during routine maintenance one can use the following 2 options:

- Add a second IlSCO GBL-4DBT grounding lug on the opposite corner of the array
- Use automotive jumper cables to reconnect broken grounding path during maintenance

Multiple Use Grounding Pins: Grounding pins within the Panel Clamp assemblies are multiple use bonding/grounding devices. Module must be adjusted if panel clamps are loosened so there is fresh metal for the grounding pin to pierce when retightened.

Grounding Method: The Quick Rack™ Rail-Free Mounting System by Quick Mount PV® has integrated grounding by use of grounding pins located on each panel clamp, whether it be a 2 inch or 8 inch panel clamp. The grounding pin on the clamp pierces the module frame by torquing a serrated flange nut on the clamp to 13 ft-lbs once the module frame has been inserted into the clamp (see graphic below). The panel clamps electrically bond all module frames together in a single array. Only one IlSCO GBL-4DBT grounding lug is required for an array, limited to 300 modules. The grounding lug must be installed per Quick Mount PV instructions and use the supplied stainless steel hardware. The grounding of the entire system is intended to be in accordance with the latest edition of the National Electrical Code, including NEC 250: Grounding and Bonding, and NEC 690: Solar Photovoltaic Systems. See page **Ref-18** for grounding path diagram.

Panel Clamps with Integrated Grounding Pins

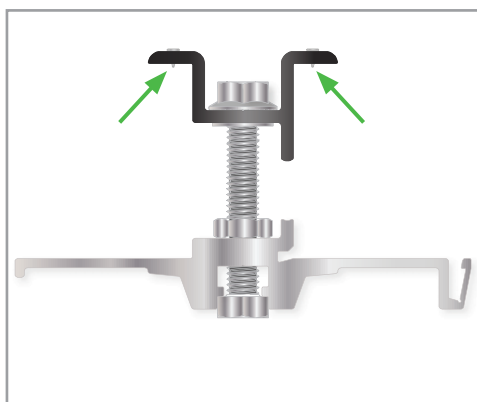

Each panel clamp has integrated grounding pins.

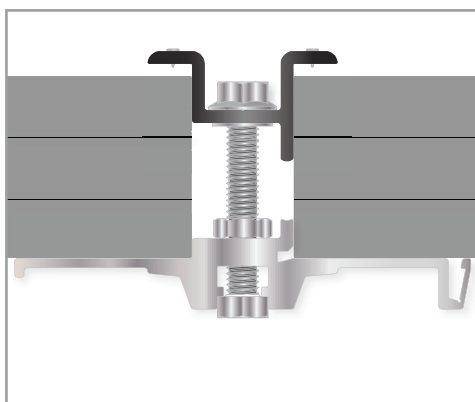

Once both modules have been inserted, tighten clamp down. The clamps can be loosened and re-tightened up to 10 times without compromising the grounding function of the pins.

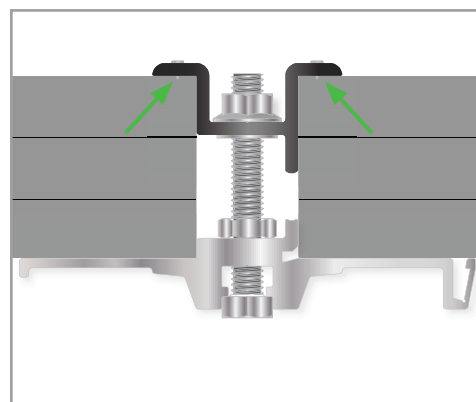

The module is grounded when pins bite into module frame.

Grounding Path Diagram

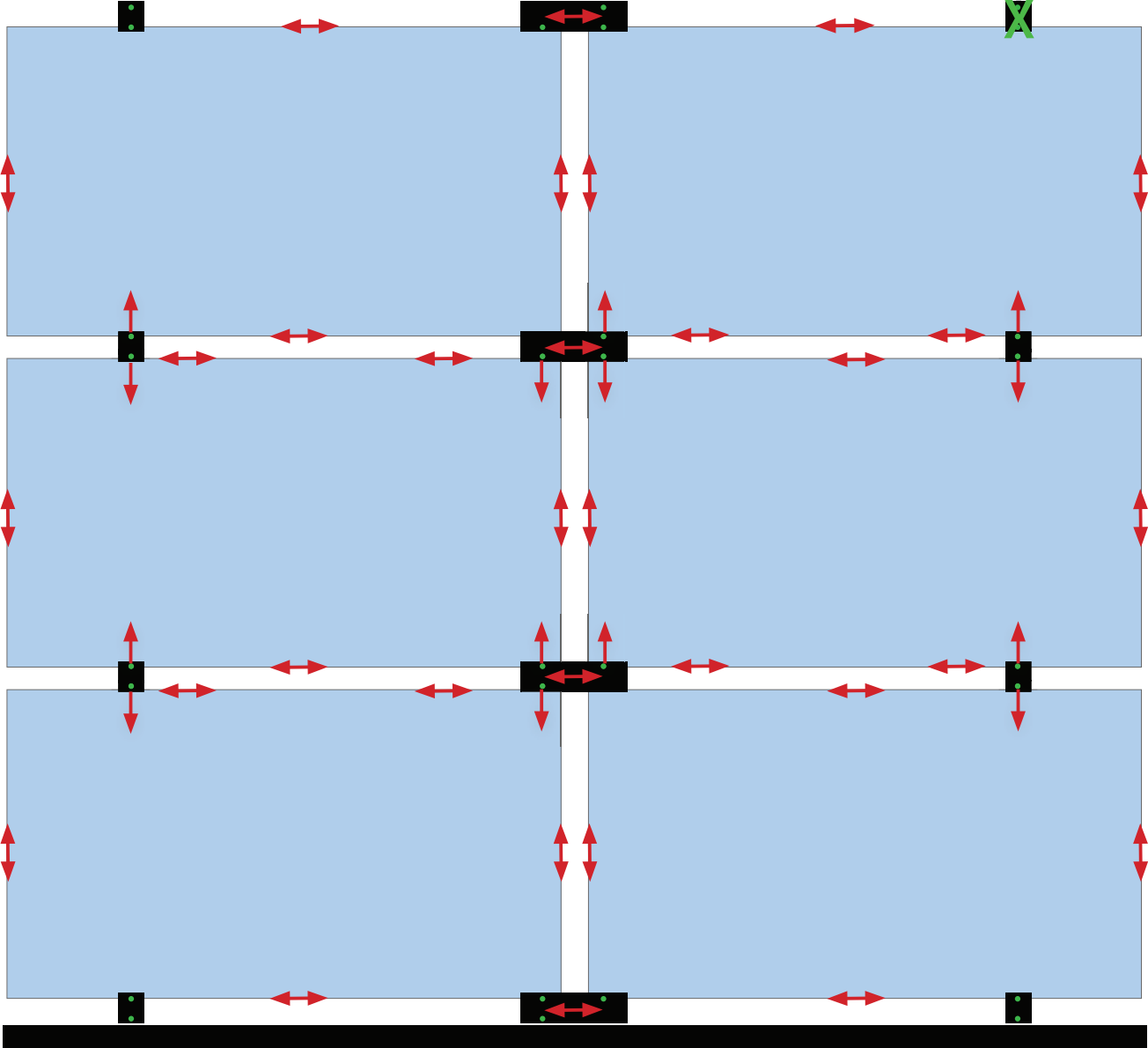
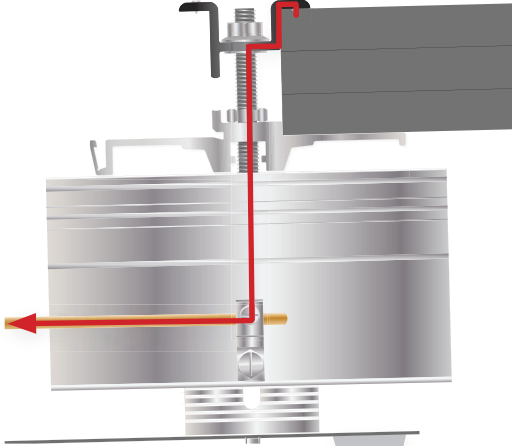
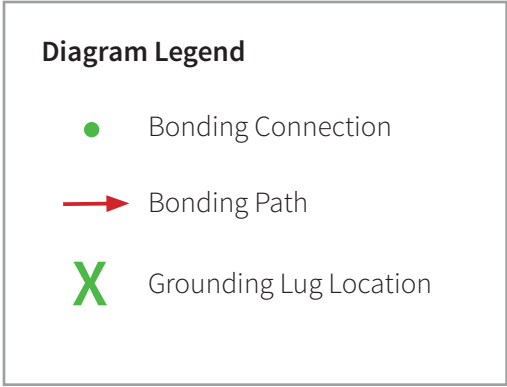

E. System Specifications & Ratings

- Maximum system size: 100ft x 100ft
- Landscape or portrait orientation
- Maximum number of modules: 300
- Torque Specs:
 - Panel Clamps (5/16"-18 bolted connection) = 13 ft-lbs minimum/20 ft-lbs maximum
 - Top Slider Bolt (1/4"-20 bolted connection) = 6 ft-lbs
 - Grounding Lug Connection Bolt (10-32 bolted connection) = 35 in-lbs
 - Grounding Lug Wire Set Screw:
 - » 4-6 AWG: 35 in-lbs
 - » 8 AWG: 25 in-lbs
 - » 10-14 AWG: 20 in-lbs
- Maximum Fuse Rating: 20 Amps
- Fire Rating: For a non-integral module or panel, the assembly is to be mounted over a fire resistant roof covering rated for the application. Quick Rack and Type I & 2 listed panels comply with a Class A fire rating when mounted at all possible Quick Rack Base Mount position both with and without the skirt on the front face of the array.

F. Engineering Drawings

| ITEM NO. | DESCRIPTION | QTY. |
|----------|---|------|
| 1 | FLASHING, 9" X 12" X .050", 5052, MILL | 1 |
| 2 | QBLOCK SLIDER, QUICK RACK, 2", 6061-T6, MILL | 1 |
| 3 | TOP SLIDER, QUICK RACK, 6", 6061-T6/6005A-T61, MILL | 1 |
| 4 | CAP SCREW, CUSTOM HEX HEAD, 1/4"-20 X 7/8" UNC-2A, 1/2" HEAD, 18-8 SS | 1 |
| 5 | NUT, SERRATED FLANGE, HEX, 1/4"-20, UNC-2B, 18-8 SS | 1 |
| 6 | STRUCTURAL SCREW, QMPV, T-30 HEX WASHER HEAD, 5/16" X 4-1/2", 18-8SS | 1 |
| 7 | WASHER, SEALING, 5/16" ID X 3/4" OD, EPDM BONDED SS | 1 |
| 8 | SCREW COVER, QBLOCK SLIDER, QUICK RACK, EPDM | 1 |

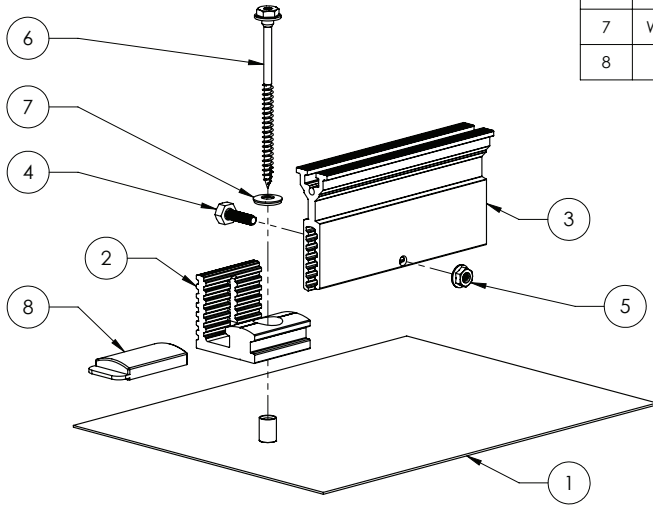

Quick Mount PV®

TITLE:
**QMQR-BM: QUICK RACK, V1.1,
BASE MOUNT ASSEMBLY**

| | | | |
|---|------------|-----------------|--------------|
| UNLESS OTHERWISE SPECIFIED: DIMENSIONS ARE IN INCHES TOLERANCES: FRACTIONAL ± 1/8 TWO PLACE DECIMAL ± .18 THREE PLACE DECIMAL ± .125 | SIZE | DRAWN BY: RAD | REV |
| | A | DATE: 6/19/2015 | 2 |
| | SCALE: 1:3 | WEIGHT: 1.49 | SHEET 1 OF 2 |

PROPRIETARY AND CONFIDENTIAL
THE INFORMATION CONTAINED IN THIS DRAWING IS THE SOLE PROPERTY OF QUICK MOUNT PV. ANY REPRODUCTION IN PART OR AS A WHOLE WITHOUT THE WRITTEN PERMISSION OF QUICK MOUNT PV IS PROHIBITED.

DO NOT SCALE DRAWING

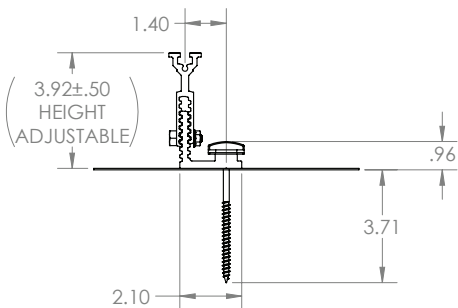
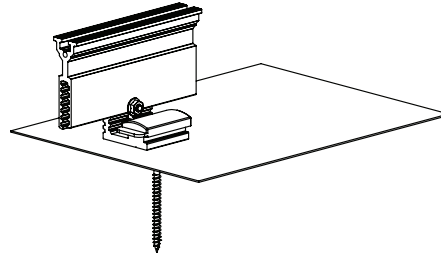
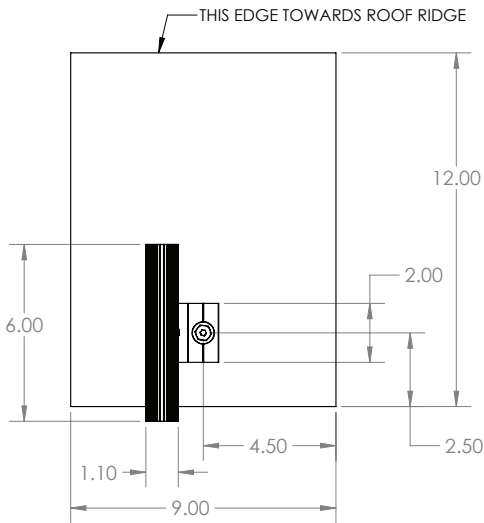

Quick Mount PV®

TITLE:
**QMQR-BM: QUICK RACK, V1.1,
BASE MOUNT ASSEMBLY**

| | | | |
|---|------------|-----------------|--------------|
| UNLESS OTHERWISE SPECIFIED: DIMENSIONS ARE IN INCHES TOLERANCES: FRACTIONAL ± 1/8 TWO PLACE DECIMAL ± .18 THREE PLACE DECIMAL ± .125 | SIZE | DRAWN BY: RAD | REV |
| | A | DATE: 6/19/2015 | 2 |
| | SCALE: 1:4 | WEIGHT: 1.49 | SHEET 2 OF 2 |

PROPRIETARY AND CONFIDENTIAL
THE INFORMATION CONTAINED IN THIS DRAWING IS THE SOLE PROPERTY OF QUICK MOUNT PV. ANY REPRODUCTION IN PART OR AS A WHOLE WITHOUT THE WRITTEN PERMISSION OF QUICK MOUNT PV IS PROHIBITED.

DO NOT SCALE DRAWING

| ITEM NO. | DESCRIPTION | QTY. |
|----------|---|------|
| 1 | CLAMP BASE, QUICK RACK V1.1, 2", 6005A-T5/6061-T6, MILL | 1 |
| 2 | PANEL CLAMP, 33MM, QUICK RACK, V1.1, 2", 6005A-T5/6005A-T61/6061-T6, BRONZE | 1 |
| 3 | CAP SCREW, HEX HEAD, 5/16"-18 X 2" UNC-2A, 18-8 SS | 1 |
| 4 | NUT, JAM, HEX, 5/16-18, UNC-2B, 18-8 SS | 1 |
| 5 | RETAINER RING, EXTERNAL PUSH-ON, 5/16", CIRCULAR, PLASTIC | 1 |
| 6 | NUT, SERRATED FLANGE, HEX, 5/16"-18, UNC-2B, 18-8 SS | 1 |

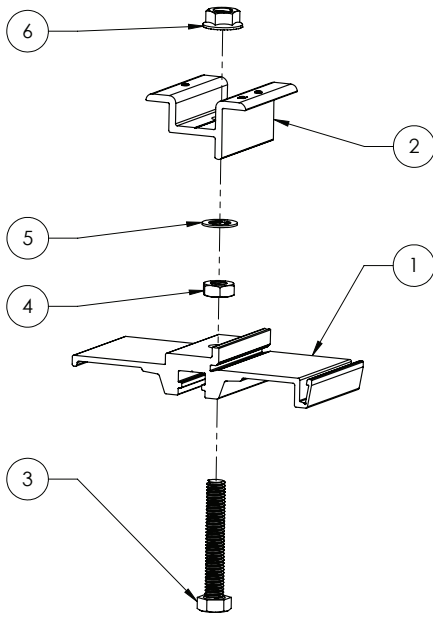

Quick Mount PV[®]

TITLE:
QMQR-CP33.2: QUICK RACK V1.1,
33MM CLAMP ASSEMBLY, 2 INCH

| | | | |
|---|------------|----------------|--------------|
| UNLESS OTHERWISE SPECIFIED: DIMENSIONS ARE IN INCHES TOLERANCES: FRACTIONAL ± 1/8 TWO PLACE DECIMAL ±.18 THREE PLACE DECIMAL ±.125 | SIZE | DRAWN BY: CAL | REV |
| | A | DATE: 7/8/2015 | 2 |
| | SCALE: 1:2 | WEIGHT: 0.34 | SHEET 1 OF 2 |

PROPRIETARY AND CONFIDENTIAL
THE INFORMATION CONTAINED IN THIS DRAWING IS THE SOLE PROPERTY OF QUICK MOUNT PV. ANY REPRODUCTION IN PART OR AS A WHOLE WITHOUT THE WRITTEN PERMISSION OF QUICK MOUNT PV IS PROHIBITED.

DO NOT SCALE DRAWING

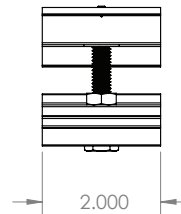
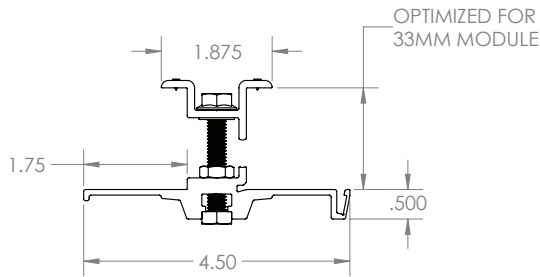
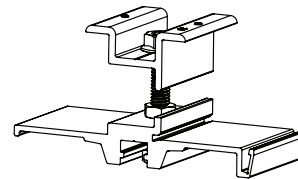

Quick Mount PV[®]

TITLE:
QMQR-CP33.2: QUICK RACK V1.1,
33MM CLAMP ASSEMBLY, 2 INCH

| | | | |
|---|------------|----------------|--------------|
| UNLESS OTHERWISE SPECIFIED: DIMENSIONS ARE IN INCHES TOLERANCES: FRACTIONAL ± 1/8 TWO PLACE DECIMAL ±.18 THREE PLACE DECIMAL ±.125 | SIZE | DRAWN BY: CAL | REV |
| | A | DATE: 7/8/2015 | 2 |
| | SCALE: 1:2 | WEIGHT: 0.34 | SHEET 2 OF 2 |

PROPRIETARY AND CONFIDENTIAL
THE INFORMATION CONTAINED IN THIS DRAWING IS THE SOLE PROPERTY OF QUICK MOUNT PV. ANY REPRODUCTION IN PART OR AS A WHOLE WITHOUT THE WRITTEN PERMISSION OF QUICK MOUNT PV IS PROHIBITED.

DO NOT SCALE DRAWING

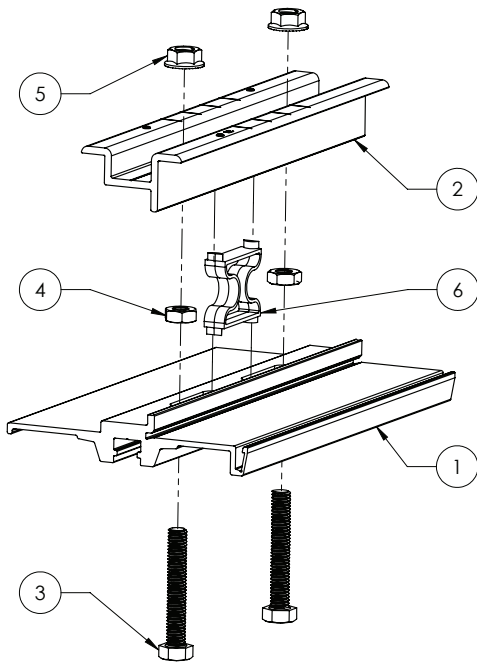

| ITEM NO. | DESCRIPTION | QTY. |
|----------|---|------|
| 1 | CLAMP BASE, QUICK RACK V1.1, 8", 6005A-T5/6061-T6, MILL | 1 |
| 2 | PANEL CLAMP, 33MM, QUICK RACK, V1.1, 8", 6005A-T5/6005A-T61/6061-T6, BRONZE | 1 |
| 3 | CAP SCREW, HEX HEAD, 5/16"-18 X 2" UNC-2A, 18-8 SS | 2 |
| 4 | NUT, JAM, HEX, 5/16-18, UNC-2B, 18-8 SS | 2 |
| 5 | NUT, SERRATED FLANGE, HEX, 5/16"-18, UNC-2B, 18-8 SS | 2 |
| 6 | CLAMP SPRING, 8", QUICK RACK, V1.1, NYLON 66, BLACK | 1 |

PROPRIETARY AND CONFIDENTIAL
 THE INFORMATION CONTAINED IN THIS DRAWING IS THE SOLE PROPERTY OF QUICK MOUNT PV. ANY REPRODUCTION IN PART OR AS A WHOLE WITHOUT THE WRITTEN PERMISSION OF QUICK MOUNT PV IS PROHIBITED.

DO NOT SCALE DRAWING

Quick Mount PV[®]

TITLE:
QMQR-CP33.8: QUICK RACK V1.1, 33MM CLAMP ASSEMBLY, 8 INCH

| | | | |
|---|------------------|-----------------------------------|-----------------|
| UNLESS OTHERWISE SPECIFIED: DIMENSIONS ARE IN INCHES TOLERANCES: FRACTIONAL ± 1/8 TWO PLACE DECIMAL ± .18 THREE PLACE DECIMAL ± .125 | SIZE A | DRAWN BY: RAD DATE: 11/12/2015 | REV 3 |
| | SCALE: 1:2 | WEIGHT: 1.20 | SHEET 1 OF 2 |

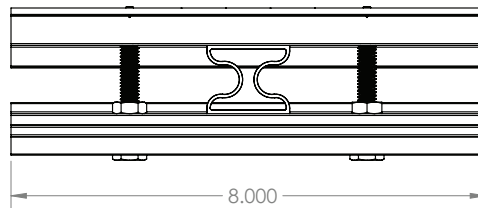
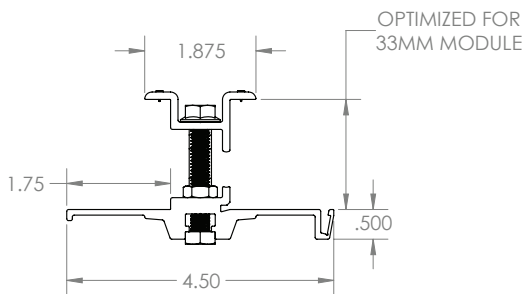
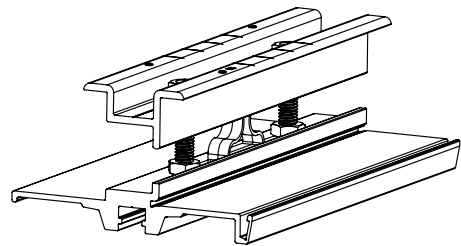

PROPRIETARY AND CONFIDENTIAL
 THE INFORMATION CONTAINED IN THIS DRAWING IS THE SOLE PROPERTY OF QUICK MOUNT PV. ANY REPRODUCTION IN PART OR AS A WHOLE WITHOUT THE WRITTEN PERMISSION OF QUICK MOUNT PV IS PROHIBITED.

DO NOT SCALE DRAWING

Quick Mount PV[®]

TITLE:
QMQR-CP33.8: QUICK RACK V1.1, 33MM CLAMP ASSEMBLY, 8 INCH

| | | | |
|---|------------------|-----------------------------------|-----------------|
| UNLESS OTHERWISE SPECIFIED: DIMENSIONS ARE IN INCHES TOLERANCES: FRACTIONAL ± 1/8 TWO PLACE DECIMAL ± .18 THREE PLACE DECIMAL ± .125 | SIZE A | DRAWN BY: RAD DATE: 11/12/2015 | REV 3 |
| | SCALE: 1:2 | WEIGHT: 1.20 | SHEET 2 OF 2 |

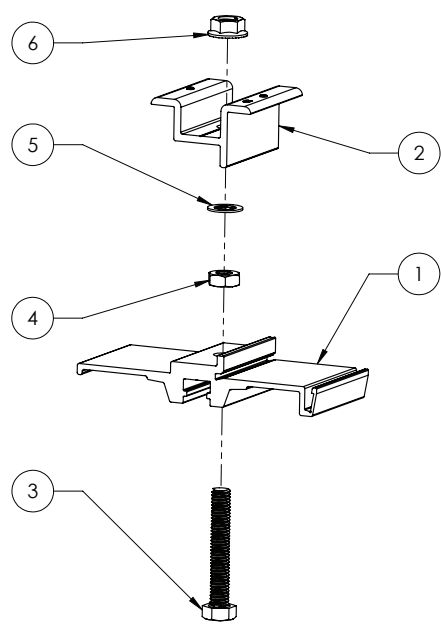

| ITEM NO. | DESCRIPTION | QTY. |
|----------|---|------|
| 1 | CLAMP BASE, QUICK RACK V1.1, 2", 6005A-T5/6061-T6, MILL | 1 |
| 2 | PANEL CLAMP, 35MM, QUICK RACK, V1.1, 2", 6005A-T5/6005A-T61/6061-T6, BRONZE | 1 |
| 3 | CAP SCREW, HEX HEAD, 5/16"-18 X 2" UNC-2A, 18-8 SS | 1 |
| 4 | NUT, JAM, HEX, 5/16-18, UNC-2B, 18-8 SS | 1 |
| 5 | RETAINER RING, EXTERNAL PUSH-ON, 5/16", CIRCULAR, PLASTIC | 1 |
| 6 | NUT, SERRATED FLANGE, HEX, 5/16"-18, UNC-2B, 18-8 SS | 1 |

Quick Mount PV[®]

TITLE:
**QMQR-CP35.2: QUICK RACK V1.1,
35MM CLAMP ASSEMBLY, 2 INCH**

| | | | |
|---|------------|----------------|--------------|
| UNLESS OTHERWISE SPECIFIED: DIMENSIONS ARE IN INCHES TOLERANCES: FRACTIONAL ± 1/8 TWO PLACE DECIMAL ± .18 THREE PLACE DECIMAL ± .125 | SIZE | DRAWN BY: CAL | REV |
| | A | DATE: 7/8/2015 | 6 |
| | SCALE: 1:2 | WEIGHT: 0.34 | SHEET 1 OF 2 |

DO NOT SCALE DRAWING

PROPRIETARY AND CONFIDENTIAL
THE INFORMATION CONTAINED IN THIS DRAWING IS THE SOLE PROPERTY OF QUICK MOUNT PV. ANY REPRODUCTION IN PART OR AS A WHOLE WITHOUT THE WRITTEN PERMISSION OF QUICK MOUNT PV IS PROHIBITED.

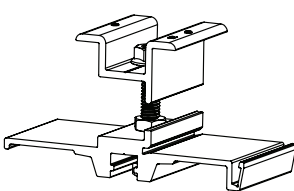
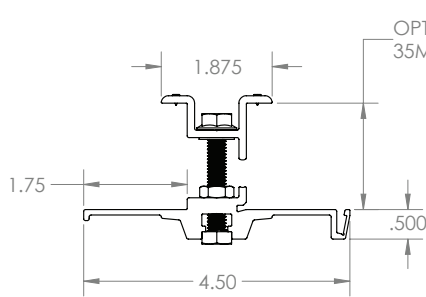
OPTIMIZED FOR
35MM MODULE

Quick Mount PV[®]

TITLE:
**QMQR-CP35.2: QUICK RACK V1.1,
35MM CLAMP ASSEMBLY, 2 INCH**

| | | | |
|---|------------|----------------|--------------|
| UNLESS OTHERWISE SPECIFIED: DIMENSIONS ARE IN INCHES TOLERANCES: FRACTIONAL ± 1/8 TWO PLACE DECIMAL ± .18 THREE PLACE DECIMAL ± .125 | SIZE | DRAWN BY: CAL | REV |
| | A | DATE: 7/8/2015 | 6 |
| | SCALE: 1:2 | WEIGHT: 0.34 | SHEET 2 OF 2 |

DO NOT SCALE DRAWING

PROPRIETARY AND CONFIDENTIAL
THE INFORMATION CONTAINED IN THIS DRAWING IS THE SOLE PROPERTY OF QUICK MOUNT PV. ANY REPRODUCTION IN PART OR AS A WHOLE WITHOUT THE WRITTEN PERMISSION OF QUICK MOUNT PV IS PROHIBITED.

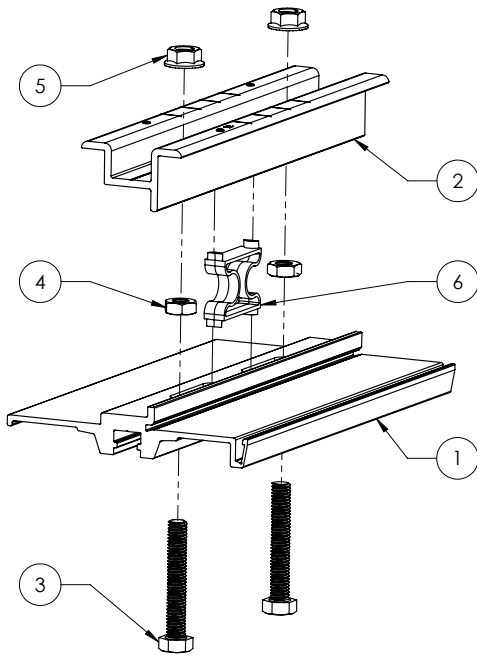

| ITEM NO. | DESCRIPTION | QTY. |
|----------|---|------|
| 1 | CLAMP BASE, QUICK RACK V1.1, 8", 6005A-T5/6061-T6, MILL | 1 |
| 2 | PANEL CLAMP, 35MM, QUICK RACK, V1.1, 8", 6005A-T5/6005A-T61/6061-T6, BRONZE | 1 |
| 3 | CAP SCREW, HEX HEAD, 5/16"-18 X 2" UNC-2A, 18-8 SS | 2 |
| 4 | NUT, JAM, HEX, 5/16-18, UNC-2B, 18-8 SS | 2 |
| 5 | NUT, SERRATED FLANGE, HEX, 5/16"-18, UNC-2B, 18-8 SS | 2 |
| 6 | CLAMP SPRING, 8 INCH, QUICK RACK, V1.1, NYLON 66, BLACK | 1 |

PROPRIETARY AND CONFIDENTIAL
 THE INFORMATION CONTAINED IN THIS DRAWING IS THE SOLE PROPERTY OF QUICK MOUNT PV. ANY REPRODUCTION IN PART OR AS A WHOLE WITHOUT THE WRITTEN PERMISSION OF QUICK MOUNT PV IS PROHIBITED.

DO NOT SCALE DRAWING

Quick Mount PV®

TITLE:
QMQR-CP35.8: QUICK RACK V1.1, 35MM CLAMP ASSEMBLY, 8 INCH

| | | | |
|---|------------------|-----------------------------------|-----------------|
| UNLESS OTHERWISE SPECIFIED: DIMENSIONS ARE IN INCHES TOLERANCES: FRACTIONAL ± 1/8 TWO PLACE DECIMAL ± .18 THREE PLACE DECIMAL ± .125 | SIZE A | DRAWN BY: RAD DATE: 11/12/2015 | REV 7 |
| SCALE: 1:2 | | WEIGHT: 1.21 | SHEET 1 OF 2 |

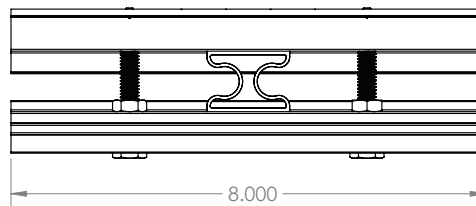
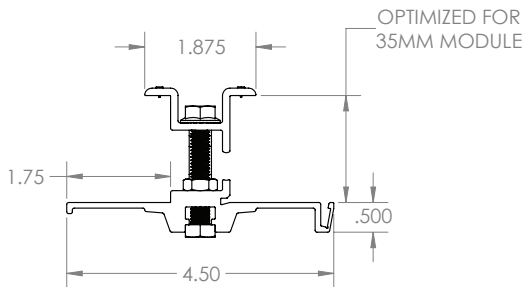
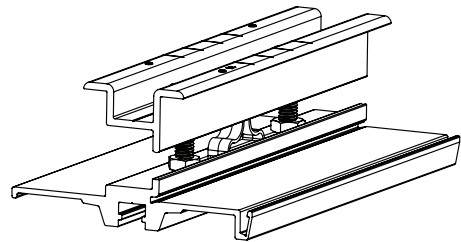

PROPRIETARY AND CONFIDENTIAL
 THE INFORMATION CONTAINED IN THIS DRAWING IS THE SOLE PROPERTY OF QUICK MOUNT PV. ANY REPRODUCTION IN PART OR AS A WHOLE WITHOUT THE WRITTEN PERMISSION OF QUICK MOUNT PV IS PROHIBITED.

DO NOT SCALE DRAWING

Quick Mount PV®

TITLE:
QMQR-CP35.8: QUICK RACK V1.1, 35MM CLAMP ASSEMBLY, 8 INCH

| | | | |
|---|------------------|-----------------------------------|-----------------|
| UNLESS OTHERWISE SPECIFIED: DIMENSIONS ARE IN INCHES TOLERANCES: FRACTIONAL ± 1/8 TWO PLACE DECIMAL ± .18 THREE PLACE DECIMAL ± .125 | SIZE A | DRAWN BY: RAD DATE: 11/12/2015 | REV 7 |
| SCALE: 1:2 | | WEIGHT: 1.21 | SHEET 2 OF 2 |

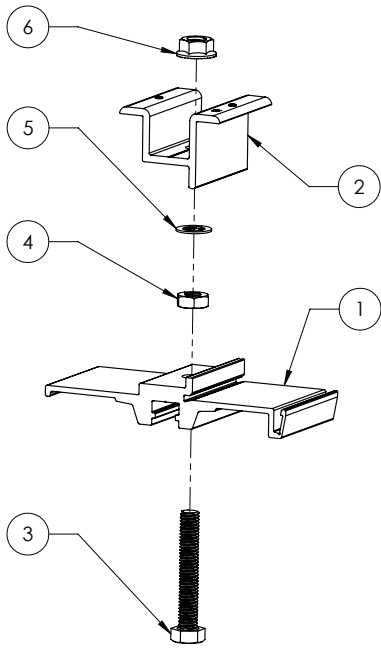

| ITEM NO. | DESCRIPTION | QTY. |
|----------|---|------|
| 1 | CLAMP BASE, QUICK RACK V1.1, 2", 6005A-T5/6061-T6, MILL | 1 |
| 2 | PANEL CLAMP, 40MM, QUICK RACK, V1.1, 2", 6005A-T5/6005A-T61/6061-T6, BRONZE | 1 |
| 3 | CAP SCREW, HEX HEAD, 5/16"-18 X 2" UNC-2A, 18-8 SS | 1 |
| 4 | NUT, JAM, HEX, 5/16-18, UNC-2B, 18-8 SS | 1 |
| 5 | RETAINER RING, EXTERNAL PUSH-ON, 5/16", CIRCULAR, PLASTIC | 1 |
| 6 | NUT, SERRATED FLANGE, HEX, 5/16"-18, UNC-2B, 18-8 SS | 1 |

PROPRIETARY AND CONFIDENTIAL
THE INFORMATION CONTAINED IN THIS DRAWING IS THE SOLE PROPERTY OF QUICK MOUNT PV. ANY REPRODUCTION IN PART OR AS A WHOLE WITHOUT THE WRITTEN PERMISSION OF QUICK MOUNT PV IS PROHIBITED.

DO NOT SCALE DRAWING

Quick Mount PV[®]

TITLE:
QMQR-CP40.2: QUICK RACK V1.1, 40MM CLAMP ASSEMBLY, 2 INCH

| | | | |
|---|------------|----------------|--------------|
| UNLESS OTHERWISE SPECIFIED: DIMENSIONS ARE IN INCHES TOLERANCES: FRACTIONAL ± 1/8 TWO PLACE DECIMAL ± .18 THREE PLACE DECIMAL ± .125 | SIZE | DRAWN BY: CAL | REV |
| | A | DATE: 7/8/2015 | 5 |
| | SCALE: 1:2 | WEIGHT: 0.35 | SHEET 1 OF 2 |

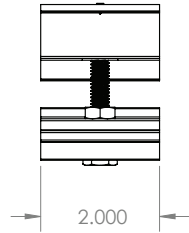
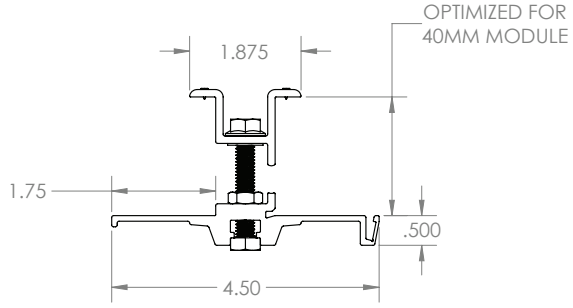
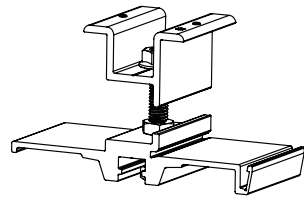

PROPRIETARY AND CONFIDENTIAL
THE INFORMATION CONTAINED IN THIS DRAWING IS THE SOLE PROPERTY OF QUICK MOUNT PV. ANY REPRODUCTION IN PART OR AS A WHOLE WITHOUT THE WRITTEN PERMISSION OF QUICK MOUNT PV IS PROHIBITED.

DO NOT SCALE DRAWING

Quick Mount PV[®]

TITLE:
QMQR-CP40.2: QUICK RACK V1.1, 40MM CLAMP ASSEMBLY, 2 INCH

| | | | |
|---|------------|----------------|--------------|
| UNLESS OTHERWISE SPECIFIED: DIMENSIONS ARE IN INCHES TOLERANCES: FRACTIONAL ± 1/8 TWO PLACE DECIMAL ± .18 THREE PLACE DECIMAL ± .125 | SIZE | DRAWN BY: CAL | REV |
| | A | DATE: 7/8/2015 | 5 |
| | SCALE: 1:2 | WEIGHT: 0.35 | SHEET 2 OF 2 |

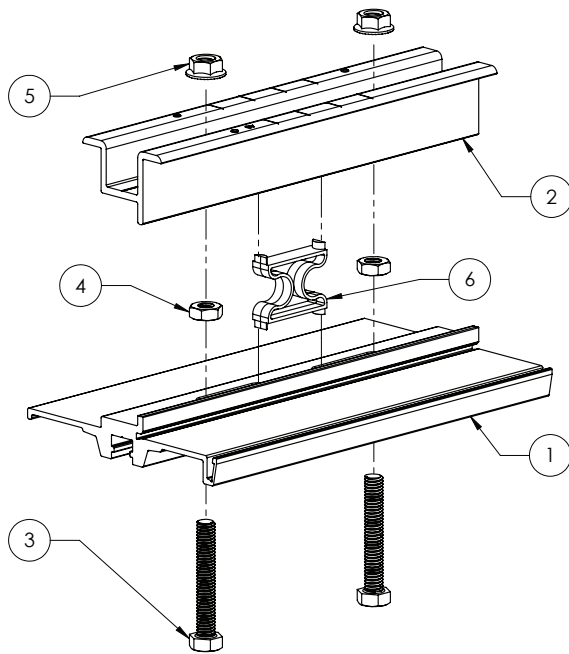

| ITEM NO. | DESCRIPTION | QTY. |
|----------|---|------|
| 1 | CLAMP BASE, QUICK RACK V1.1, 8", 6005A-T5/6061-T6, MILL | 1 |
| 2 | PANEL CLAMP, 40MM, QUICK RACK, V1.1, 8", 6005A-T5/6005A-T61/6061-T6, BRONZE | 1 |
| 3 | CAP SCREW, HEX HEAD, 5/16"-18 X 2" UNC-2A, 18-8 SS | 2 |
| 4 | NUT, JAM, HEX, 5/16-18, UNC-2B, 18-8 SS | 2 |
| 5 | NUT, SERRATED FLANGE, HEX, 5/16"-18, UNC-2B, 18-8 SS | 2 |
| 6 | CLAMP SPRING, 8 INCH, QUICK RACK, V1.1, NYLON 66, BLACK | 1 |

PROPRIETARY AND CONFIDENTIAL
THE INFORMATION CONTAINED IN THIS DRAWING IS THE SOLE PROPERTY OF QUICK MOUNT PV. ANY REPRODUCTION IN PART OR AS A WHOLE WITHOUT THE WRITTEN PERMISSION OF QUICK MOUNT PV IS PROHIBITED.

DO NOT SCALE DRAWING

Quick Mount PV®

TITLE:
QMQR-CP40.8: QUICK RACK V1.1,
40MM CLAMP ASSEMBLY, 8 INCH

| | | | |
|---|------------------|-----------------------------------|-----------------|
| UNLESS OTHERWISE SPECIFIED: DIMENSIONS ARE IN INCHES TOLERANCES: FRACTIONAL ± 1/8 TWO PLACE DECIMAL ±.18 THREE PLACE DECIMAL ±.125 | SIZE A | DRAWN BY: RAD DATE: 11/12/2015 | REV 6 |
| SCALE: 1:2 | WEIGHT: 1.25 | SHEET 1 OF 2 | |

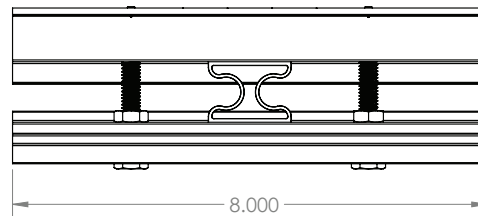
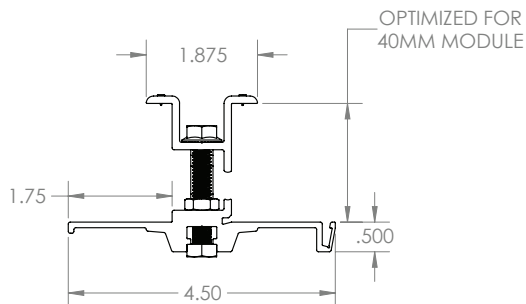
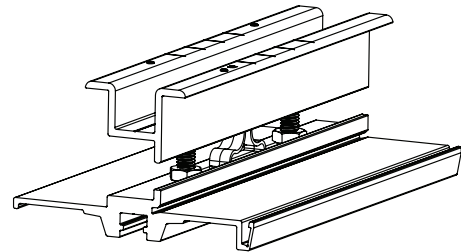

PROPRIETARY AND CONFIDENTIAL
THE INFORMATION CONTAINED IN THIS DRAWING IS THE SOLE PROPERTY OF QUICK MOUNT PV. ANY REPRODUCTION IN PART OR AS A WHOLE WITHOUT THE WRITTEN PERMISSION OF QUICK MOUNT PV IS PROHIBITED.

DO NOT SCALE DRAWING

Quick Mount PV®

TITLE:
QMQR-CP40.8: QUICK RACK V1.1,
40MM CLAMP ASSEMBLY, 8 INCH

| | | | |
|---|------------------|-----------------------------------|-----------------|
| UNLESS OTHERWISE SPECIFIED: DIMENSIONS ARE IN INCHES TOLERANCES: FRACTIONAL ± 1/8 TWO PLACE DECIMAL ±.18 THREE PLACE DECIMAL ±.125 | SIZE A | DRAWN BY: RAD DATE: 11/12/2015 | REV 6 |
| SCALE: 1:2 | WEIGHT: 1.25 | SHEET 2 OF 2 | |

| ITEM NO. | DESCRIPTION | QTY. |
|----------|--|------|
| 1 | SKIRT, QUICK RACK, V1.1, 65.80", 6063-T6, BRONZE | 1 |
| 2 | SKIRT CLIP, QUICK RACK, V1.1, 2", 6063-T6, MILL | 2 |

ITEM 1 : AVAILABLE IN 65.80" AND 66.70" LENGTHS

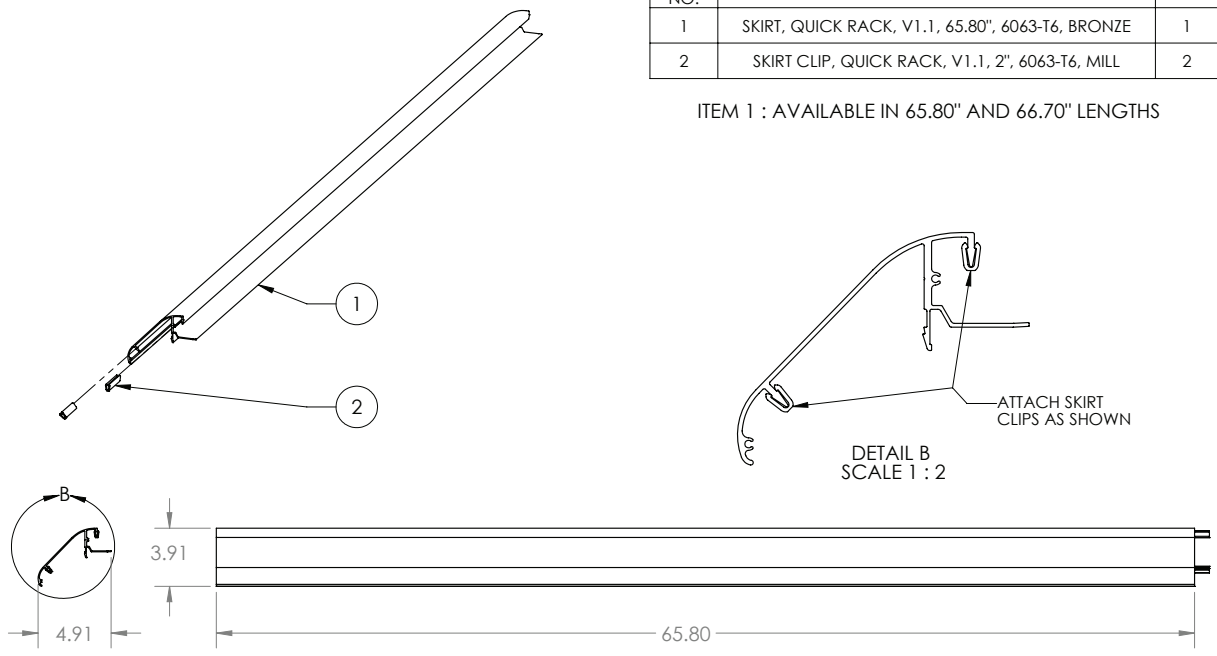

Quick Mount PV[®]

TITLE:
QMQR-SL: SKIRT ASSEMBLY, QUICK RACK, V1.1, LANDSCAPE

| | | | |
|---|------------------|----------------------------------|-----------------|
| UNLESS OTHERWISE SPECIFIED: DIMENSIONS ARE IN INCHES TOLERANCES: FRACTIONAL ± 1/8 TWO PLACE DECIMAL ±.18 THREE PLACE DECIMAL ±.125 | SIZE A | DRAWN BY: RAD DATE: 9/24/2015 | REV 2 |
|---|------------------|----------------------------------|-----------------|

SCALE: 1:8 WEIGHT: 5.94 SHEET 1 OF 1

PROPRIETARY AND CONFIDENTIAL
THE INFORMATION CONTAINED IN THIS DRAWING IS THE SOLE PROPERTY OF QUICK MOUNT PV. ANY REPRODUCTION IN PART OR AS A WHOLE WITHOUT THE WRITTEN PERMISSION OF QUICK MOUNT PV IS PROHIBITED.

| ITEM NO. | DESCRIPTION | QTY. |
|----------|---|------|
| 1 | SKIRT, QUICK RACK, V1.1, 40.125", 6063-T6, BRONZE | 1 |
| 2 | SKIRT CLIP, QUICK RACK, V1.1, 2", 6063-T6, MILL | 2 |

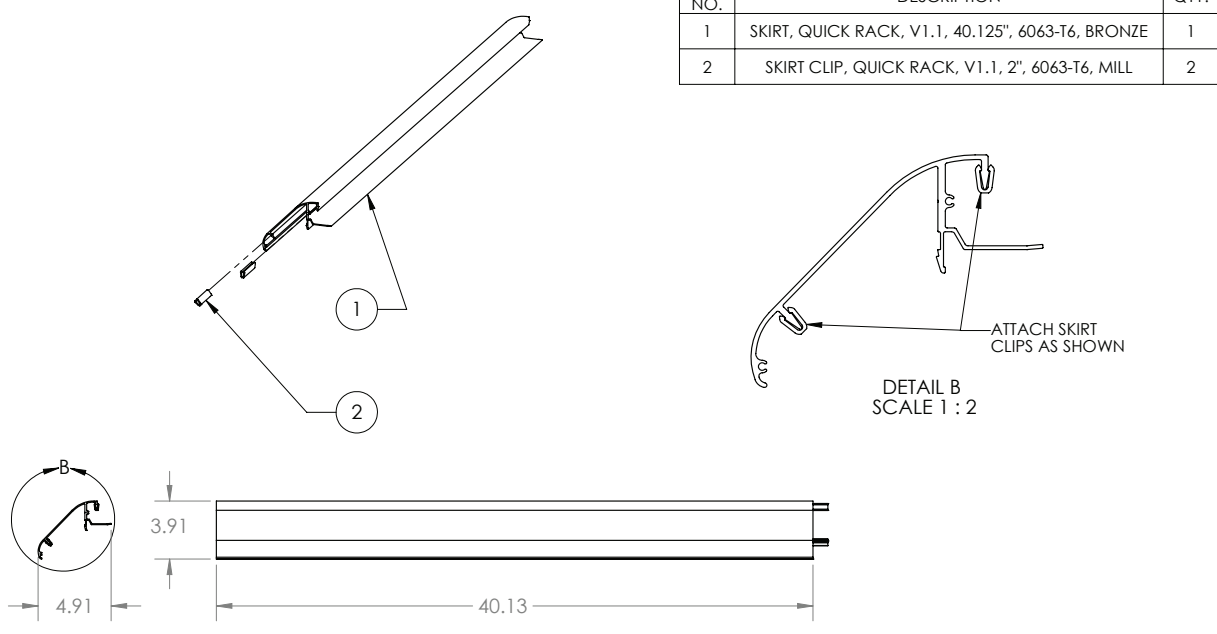

Quick Mount PV[®]

TITLE:
QMQR-SM: SKIRT ASSEMBLY, QUICK RACK, V1.1, 40.125"

| | | | |
|---|------------------|----------------------------------|-----------------|
| UNLESS OTHERWISE SPECIFIED: DIMENSIONS ARE IN INCHES TOLERANCES: FRACTIONAL ± 1/8 TWO PLACE DECIMAL ±.18 THREE PLACE DECIMAL ±.125 | SIZE A | DRAWN BY: RAD DATE: 2/28/2014 | REV 1 |
|---|------------------|----------------------------------|-----------------|

SCALE: 1:8 WEIGHT: 3.64 SHEET 1 OF 1

PROPRIETARY AND CONFIDENTIAL
THE INFORMATION CONTAINED IN THIS DRAWING IS THE SOLE PROPERTY OF QUICK MOUNT PV. ANY REPRODUCTION IN PART OR AS A WHOLE WITHOUT THE WRITTEN PERMISSION OF QUICK MOUNT PV IS PROHIBITED.

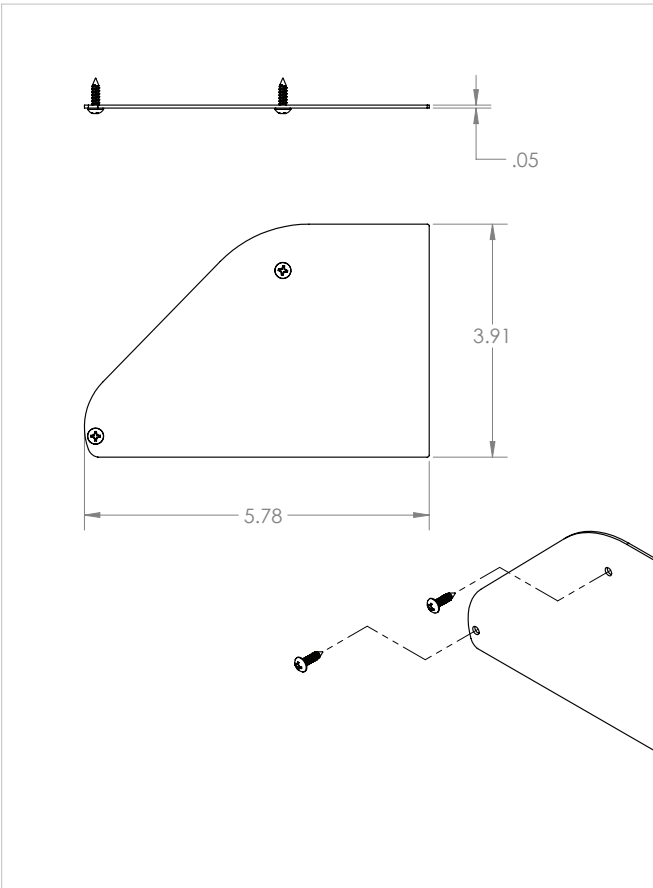

| ITEM NO. | DESCRIPTION | QTY. |
|----------|---|------|
| 1 | END CAP, SKIRT, RIGHT, QUICK RACK V1.1, 5005-H34 - BRONZE | 1 |
| 2 | END CAP, SKIRT, LEFT, QUICK RACK V1.1, 5005-H34 - BRONZE | 1 |
| 3 | SCREW, SHEET METAL, #6 X 1/2", 18-8SS - BLACK MARKOTE | 4 |

PROPRIETARY AND CONFIDENTIAL
 THE INFORMATION CONTAINED IN THIS DRAWING IS THE SOLE PROPERTY OF QUICK MOUNT PV. ANY REPRODUCTION IN PART OR AS A WHOLE WITHOUT THE WRITTEN PERMISSION OF QUICK MOUNT PV IS PROHIBITED.

DO NOT SCALE DRAWING

Quick Mount PV[®]

TITLE:
**QMQR-SC: END CAP, SKIRT,
 QUICK RACK V1.1**

| | | | |
|---|------------|-----------------|--------------|
| UNLESS OTHERWISE SPECIFIED: DIMENSIONS ARE IN INCHES TOLERANCES: FRACTIONAL ± 1/8 TWO PLACE DECIMAL ± .18 THREE PLACE DECIMAL ± .125 | SIZE | DRAWN BY: RAD | REV |
| | A | DATE: 2/28/2014 | 1 |
| | SCALE: 1:2 | WEIGHT: 0.19 | SHEET 1 OF 1 |

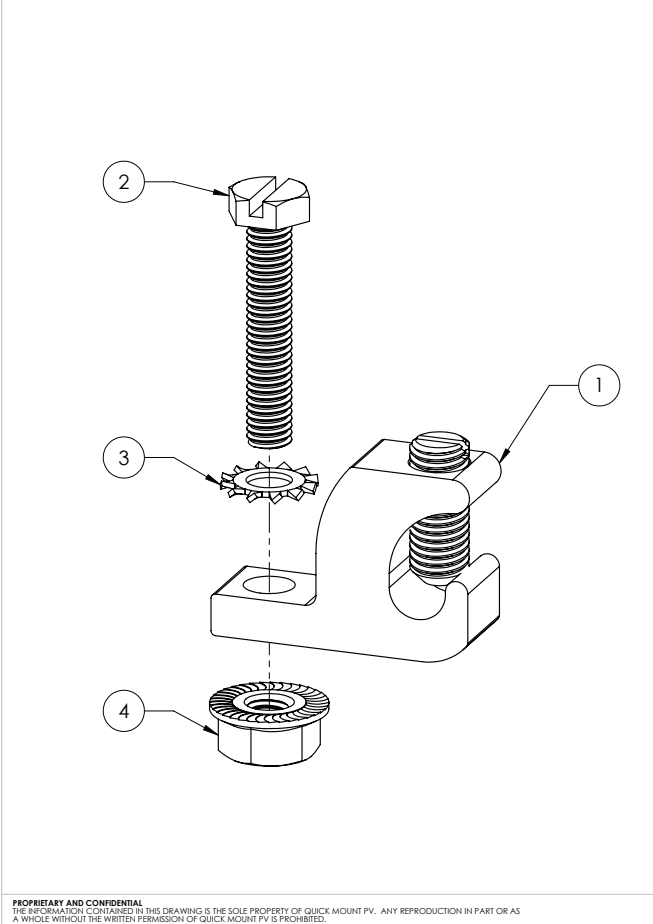

| ITEM NO. | DESCRIPTION | QTY. |
|----------|---|------|
| 1 | GROUND LUG, 4-14 AWG, COPPER-TIN PLATED, WITH SET SCREW | 1 |
| 2 | CAP SCREW, SLOTTED HEX HEAD, 10-32 X 1" UNF-2A, 18-8 SS | 1 |
| 3 | WASHER, STAR, #10, 18-8SS | 1 |
| 4 | NUT, SERRATED FLANGE, HEX, 10-32, UNF-2B, 18-8 SS | 1 |

ITEM 1: ILSCO CORP. PART NUMBER GBL-4DBT

PROPRIETARY AND CONFIDENTIAL
 THE INFORMATION CONTAINED IN THIS DRAWING IS THE SOLE PROPERTY OF QUICK MOUNT PV. ANY REPRODUCTION IN PART OR AS A WHOLE WITHOUT THE WRITTEN PERMISSION OF QUICK MOUNT PV IS PROHIBITED.

DO NOT SCALE DRAWING

Quick Mount PV[®]

TITLE:
**QMQR-GL: GROUNDING LUG
 ASSEMBLY, QUICK RACK V1.1**

| | | | |
|---|------------|-----------------|--------------|
| UNLESS OTHERWISE SPECIFIED: DIMENSIONS ARE IN INCHES TOLERANCES: FRACTIONAL ± 1/8 TWO PLACE DECIMAL ± .18 THREE PLACE DECIMAL ± .125 | SIZE | DRAWN BY: RAD | REV |
| | A | DATE: 9/22/2015 | 2 |
| | SCALE: 2:1 | WEIGHT: 0.08 | SHEET 1 OF 1 |

Notes

Notes

Notes

Quick Mount PV[®]

RESPECT THE ROOF

925-478-8269 | 2700 Mitchell Dr. | Walnut Creek, CA 94598

www.quickmountpv.com | tech@quickmountpv.com



Intertek
4008516

UL SUB 2703



Made in USA