

5. GROUND POINT ESTABLISHED BY CUSTOMER.
  4. UNLESS OTHERWISE SPECIFIED, WIRING TO BE #12 RED POSITIVE (+), BLACK NEGATIVE (-), GREEN GROUND (⊕).
  3. BATTERIES TO BE INSTALLED IN THE FIELD.
  2. CONNECTIONS TO BATTERIES TO BE COMPLETED IN THE FIELD.
  1. CONNECTIONS TO ARRAY TO BE COMPLETED IN THE FIELD.
- NOTES:



OWNERSHIP

COPYRIGHT ©2018 THE ABOVE DRAWINGS, SPECIFICATIONS, IDEAS, DESIGNS, AND ARRANGEMENTS ARE AND SHALL REMAIN THE PROPERTY OF SOLAR ELECTRIC SUPPLY AND NO PART THEREOF SHALL BE COPIED, DISCLOSED TO OTHERS, OR USED IN CONNECTION WITH ANY WORK OR PROJECT OTHER THAN THE SPECIFIED PROJECT FOR WHICH THEY HAVE BEEN PREPARED AND DEVELOPED WITHOUT THE WRITTEN CONSENT OF SOLAR ELECTRIC SUPPLY. VISUAL CONTACT WITH THESE PLANS OR SPECIFICATIONS SHALL CONSTITUTE CONCLUSIVE EVIDENCE OF ACCEPTANCE OF THESE RESTRICTIONS.

WIRING DIAGRAM

MAPPS 50-108-12

UNITS  
UNLESS OTHERWISE SPECIFIED:  
PRIMARY UNITS ARE: INCHES  
SECONDARY UNITS ARE: [mm]

REVISIONS

REV	REVISED BY	DATE

MISC

SCALE	N/A	DRAWING NUMBER	SD50-0020-SES	SIZE	A
		B.O.M. NUMBER	SB50-0020-SES		
		SHEET	1	OF	3

APPROVALS NAME	DATE
DRAWN E. RIVAS	26.SEP.18
APPROVED C. LEONARD	26.SEP.18

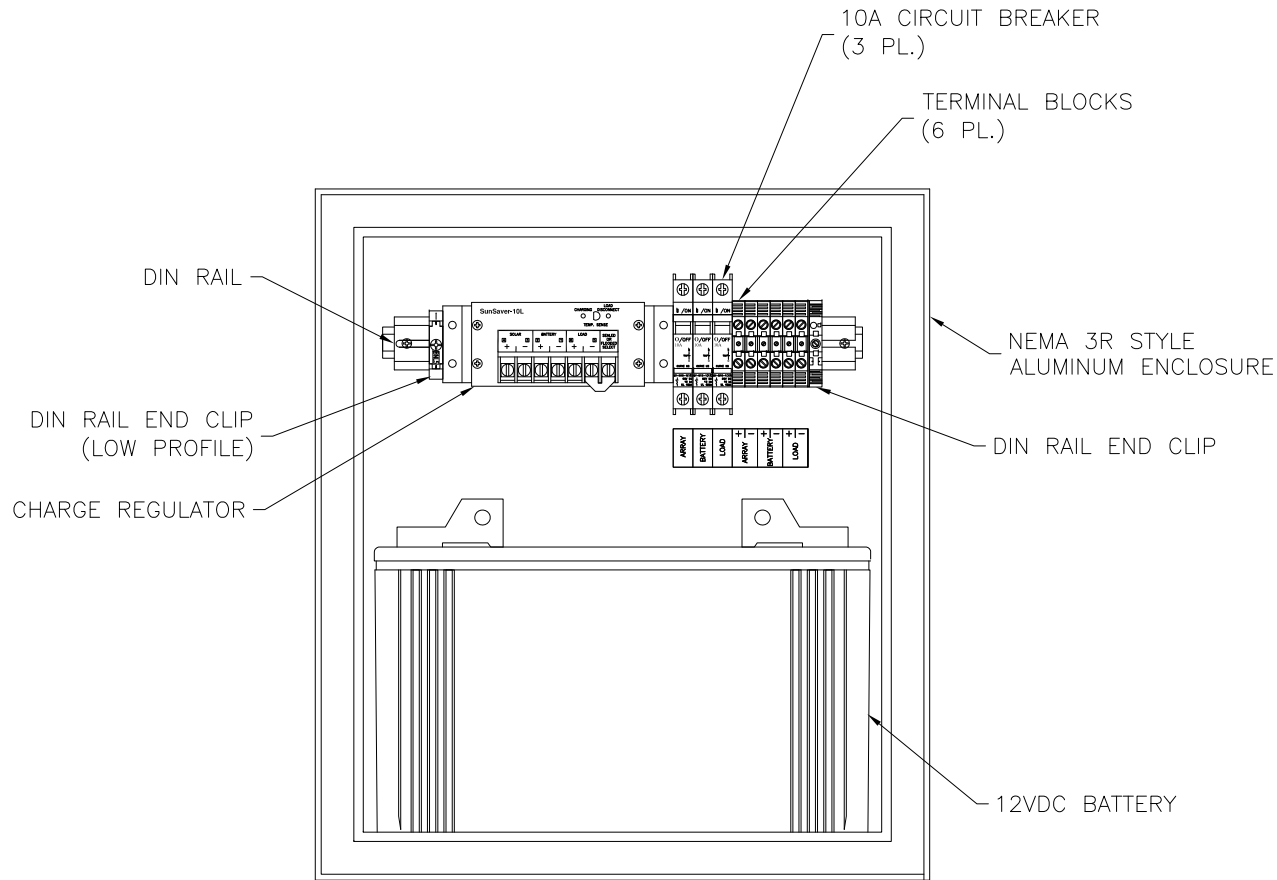

1. ENCLOSURE DOOR NOT SHOWN FOR CLARITY.  
NOTES:



OWNERSHIP

COPYRIGHT ©2018 THE ABOVE DRAWINGS, SPECIFICATIONS, IDEAS, DESIGNS, AND ARRANGEMENTS ARE AND SHALL REMAIN THE PROPERTY OF SOLAR ELECTRIC SUPPLY AND NO PART THEREOF SHALL BE COPIED, DISCLOSED TO OTHERS, OR USED IN CONNECTION WITH ANY WORK OR PROJECT OTHER THAN THE SPECIFIED PROJECT FOR WHICH THEY HAVE BEEN PREPARED AND DEVELOPED WITHOUT THE WRITTEN CONSENT OF SOLAR ELECTRIC SUPPLY. VISUAL CONTACT WITH THESE PLANS OR SPECIFICATIONS SHALL CONSTITUTE CONCLUSIVE EVIDENCE OF ACCEPTANCE OF THESE RESTRICTIONS.

ENCLOSURE LAYOUT  
MAPPS 50-108-12

UNITS  
UNLESS OTHERWISE SPECIFIED:  
PRIMARY UNITS ARE: INCHES  
SECONDARY UNITS ARE: [mm]

REVISIONS		
REV	REVISED BY	DATE

MISC

APPROVALS

SCALE N/A	DRAWING NUMBER SD50-0020-SES	DATE 26.SEP.18
	B.O.M. NUMBER SB50-0020-SES	DRAWN E. RIVAS
	SHEET 2 OF 3	APPROVED C. LEONARD

SIZE  
A

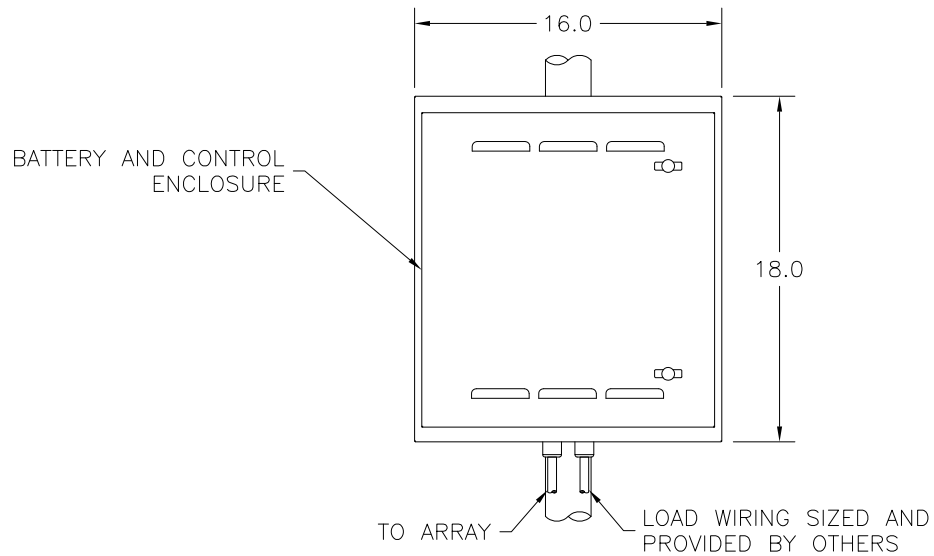
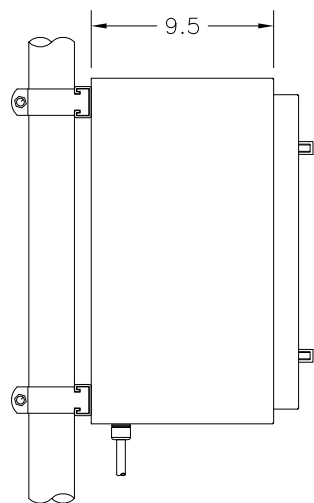
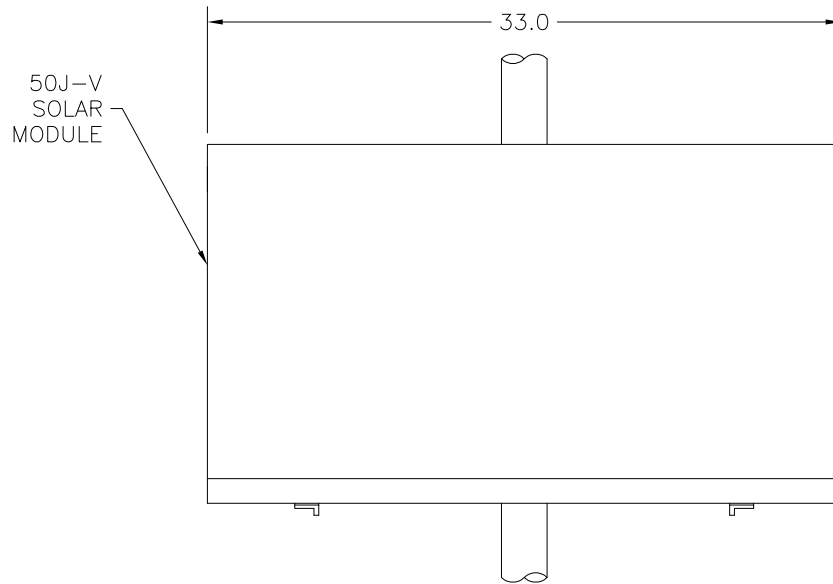
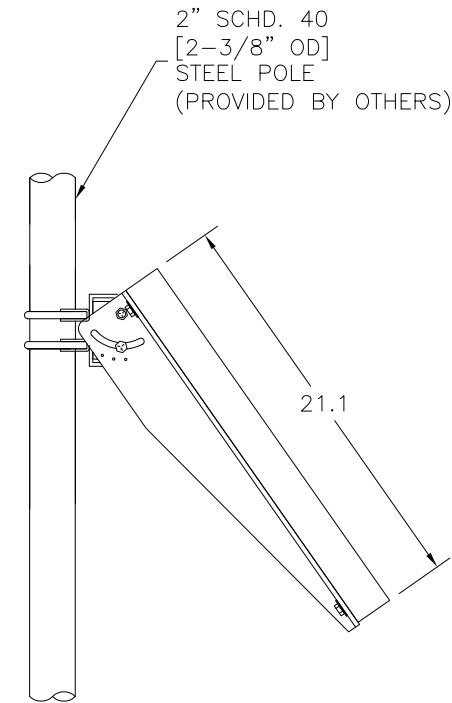

OWNERSHIP

COPYRIGHT ©2018 THE ABOVE DRAWINGS, SPECIFICATIONS, IDEAS, DESIGNS, AND ARRANGEMENTS ARE AND SHALL REMAIN THE PROPERTY OF SOLAR ELECTRIC SUPPLY AND NO PART THEREOF SHALL BE COPIED, DISCLOSED TO OTHERS, OR USED IN CONNECTION WITH ANY WORK OR PROJECT OTHER THAN THE SPECIFIED PROJECT FOR WHICH THEY HAVE BEEN PREPARED AND DEVELOPED WITHOUT THE WRITTEN CONSENT OF SOLAR ELECTRIC SUPPLY. VISUAL CONTACT WITH THESE PLANS OR SPECIFICATIONS SHALL CONSTITUTE CONCLUSIVE EVIDENCE OF ACCEPTANCE OF THESE RESTRICTIONS.

SITE LAYOUT		DATE	
MAPPS 50-108-12		26.SEP.18	
UNITS		APPROVALS NAME	
UNLESS OTHERWISE SPECIFIED: PRIMARY UNITS ARE: INCHES SECONDARY UNITS ARE: [mm]		DRAWN E. RIVAS	
REVISIONS		APPROVED C. LEONARD	
REV	REVISED BY	DATE	
MISC			
SCALE	DRAWING NUMBER	SIZE	
N/A	SD50-0020-SES	A	
	B.O.M. NUMBER		
	SB50-0020-SES		
	SHEET 3 OF 3		