

5. GROUND POINT ESTABLISHED BY CUSTOMER.
 4. UNLESS OTHERWISE SPECIFIED, WIRING TO BE #10 RED POSITIVE (+), BLACK NEGATIVE (-), GREEN GROUND (⊕).
 3. BATTERIES TO BE INSTALLED IN THE FIELD.
 2. CONNECTIONS TO BATTERIES TO BE COMPLETED IN THE FIELD.
 1. CONNECTIONS TO ARRAY TO BE COMPLETED IN THE FIELD.
- NOTES:



OWNERSHIP

COPYRIGHT ©2023 THE ABOVE DRAWINGS, SPECIFICATIONS, IDEAS, DESIGNS, AND ARRANGEMENTS ARE AND SHALL REMAIN THE PROPERTY OF SOLAR ELECTRIC SUPPLY AND NO PART THEREOF SHALL BE COPIED, DISCLOSED TO OTHERS, OR USED IN CONNECTION WITH ANY WORK OR PROJECT OTHER THAN THE SPECIFIED PROJECT FOR WHICH THEY HAVE BEEN PREPARED AND DEVELOPED WITHOUT THE WRITTEN CONSENT OF SOLAR ELECTRIC SUPPLY. VISUAL CONTACT WITH THESE PLANS OR SPECIFICATIONS SHALL CONSTITUTE CONCLUSIVE EVIDENCE OF ACCEPTANCE OF THESE RESTRICTIONS.

WIRING DIAGRAM
MAPPS 90-216-12

UNITS
UNLESS OTHERWISE SPECIFIED:
PRIMARY UNITS ARE: INCHES
SECONDARY UNITS ARE: [mm]

REVISIONS		
REV	REVISED BY	DATE

MISC

SCALE	DRAWING NUMBER	SIZE
N/A	SD50-0061-SES	A
	B.O.M. NUMBER	
	SB50-0061	
	SHEET 1 of 3	

APPROVALS	NAME	DATE
	E. RIVAS	18.JUL.23
APPROVED		

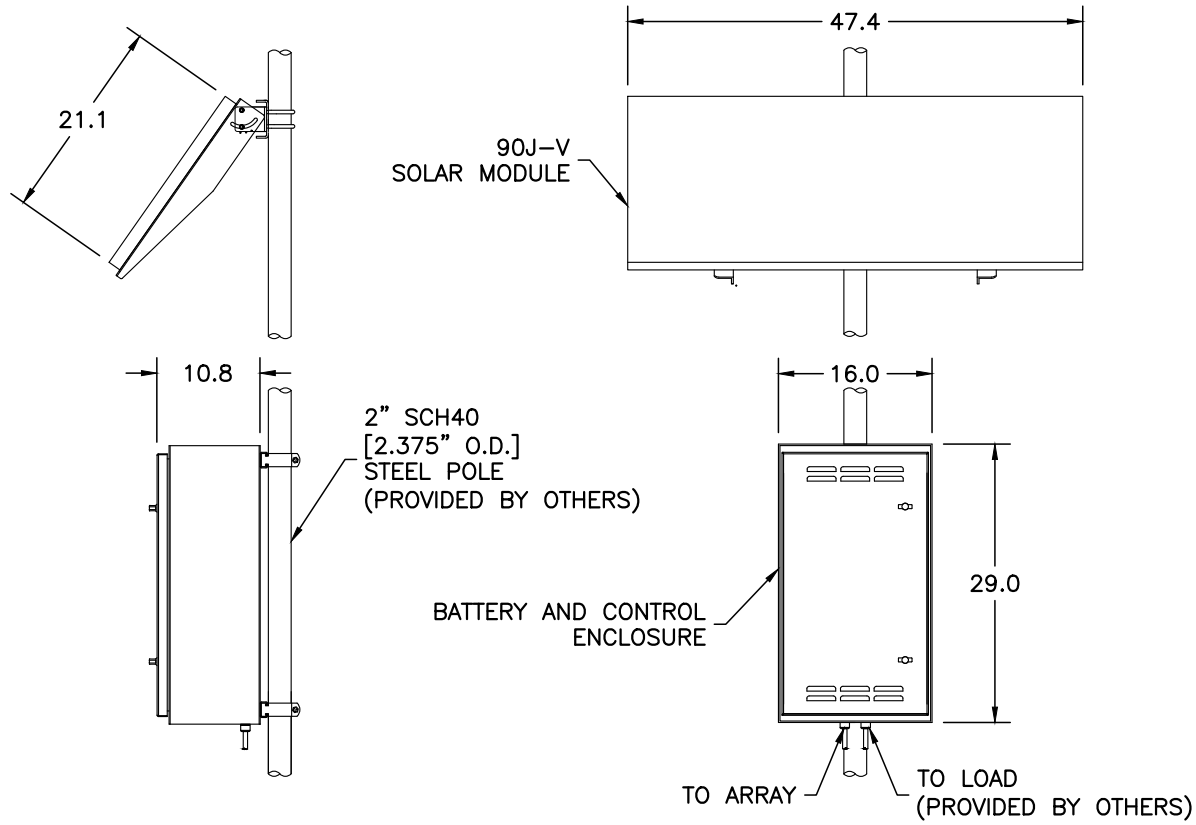

OWNERSHIP

COPYRIGHT ©2023 THE ABOVE DRAWINGS, SPECIFICATIONS, IDEAS, DESIGNS, AND ARRANGEMENTS ARE AND SHALL REMAIN THE PROPERTY OF SOLAR ELECTRIC SUPPLY AND NO PART THEREOF SHALL BE COPIED, DISCLOSED TO OTHERS, OR USED IN CONNECTION WITH ANY WORK OR PROJECT OTHER THAN THE SPECIFIED PROJECT FOR WHICH THEY HAVE BEEN PREPARED AND DEVELOPED WITHOUT THE WRITTEN CONSENT OF SOLAR ELECTRIC SUPPLY. VISUAL CONTACT WITH THESE PLANS OR SPECIFICATIONS SHALL CONSTITUTE CONCLUSIVE EVIDENCE OF ACCEPTANCE OF THESE RESTRICTIONS.

SITE LAYOUT
MAPP5 90-216-12

UNITS
UNLESS OTHERWISE SPECIFIED:
PRIMARY UNITS ARE: INCHES
SECONDARY UNITS ARE: [mm]

REVISIONS

REV	REVISED BY	DATE

MISC

SCALE	DRAWING NUMBER	SIZE
N/A	SD50-0061-SES	A
	B.O.M. NUMBER	
	SB50-0061	
	SHEET 2 of 3	

APPROVALS	NAME	DATE
	DRAWN E. RIVAS	18.JUL.23

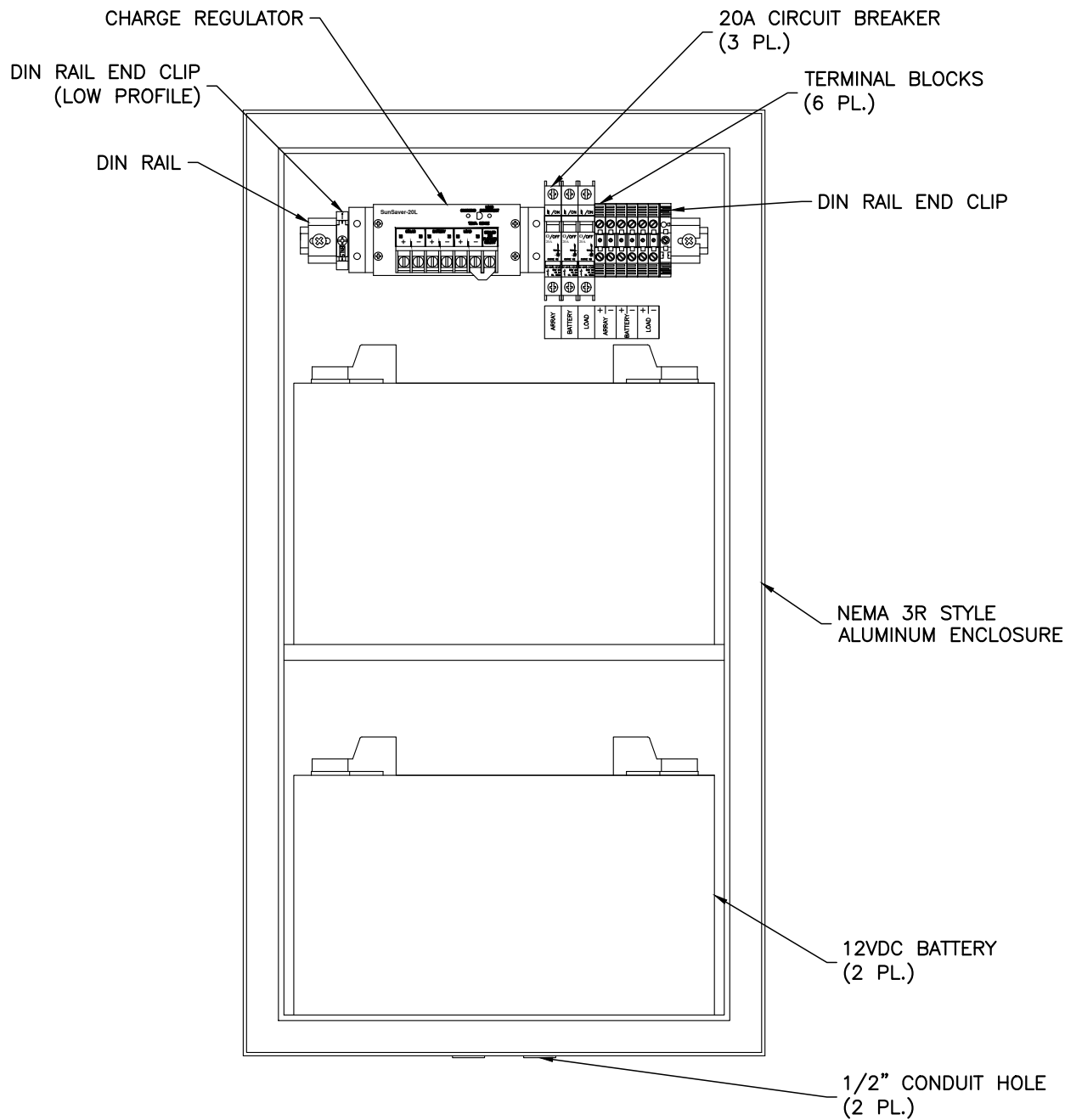

1. ENCLOSURE DOOR NOT SHOWN FOR CLARITY.
NOTES:



OWNERSHIP

COPYRIGHT ©2023 THE ABOVE DRAWINGS, SPECIFICATIONS, IDEAS, DESIGNS, AND ARRANGEMENTS ARE AND SHALL REMAIN THE PROPERTY OF SOLAR ELECTRIC SUPPLY AND NO PART THEREOF SHALL BE COPIED, DISCLOSED TO OTHERS, OR USED IN CONNECTION WITH ANY WORK OR PROJECT OTHER THAN THE SPECIFIED PROJECT FOR WHICH THEY HAVE BEEN PREPARED AND DEVELOPED WITHOUT THE WRITTEN CONSENT OF SOLAR ELECTRIC SUPPLY. VISUAL CONTACT WITH THESE PLANS OR SPECIFICATIONS SHALL CONSTITUTE CONCLUSIVE EVIDENCE OF ACCEPTANCE OF THESE RESTRICTIONS.

ENCLOSURE LAYOUT
MAPPS 90-216-12

DATE 18.JUL.23

UNITS
UNLESS OTHERWISE SPECIFIED:
PRIMARY UNITS ARE: INCHES
SECONDARY UNITS ARE: [mm]

REVISIONS

REV	REVISED BY	DATE

MISC

SCALE N/A	DRAWING NUMBER SD50-0061-SES	SIZE A
	B.O.M. NUMBER SB50-0061	
	SHEET 3 of 3	

APPROVALS NAME
DRAWN E. RIVAS

DATE
18.JUL.23

APPROVED