

5. GROUND POINT ESTABLISHED BY CUSTOMER.
 4. UNLESS OTHERWISE SPECIFIED, WIRING TO BE #10 RED POSITIVE (+), BLACK NEGATIVE (-), GREEN GROUND (\perp).
 3. BATTERIES TO BE INSTALLED IN THE FIELD.
 2. CONNECTIONS TO BATTERIES TO BE COMPLETED IN THE FIELD.
 1. CONNECTIONS TO ARRAY TO BE COMPLETED IN THE FIELD.
- NOTES:



OWNERSHIP

COPYRIGHT ©2019 THE ABOVE DRAWINGS, SPECIFICATIONS, IDEAS, DESIGNS, AND ARRANGEMENTS ARE AND SHALL REMAIN THE PROPERTY OF SOLAR ELECTRIC SUPPLY AND NO PART THEREOF SHALL BE COPIED, DISCLOSED TO OTHERS, OR USED IN CONNECTION WITH ANY WORK OR PROJECT OTHER THAN THE SPECIFIED PROJECT FOR WHICH THEY HAVE BEEN PREPARED AND DEVELOPED WITHOUT THE WRITTEN CONSENT OF SOLAR ELECTRIC SUPPLY. VISUAL CONTACT WITH THESE PLANS OR SPECIFICATIONS SHALL CONSTITUTE CONCLUSIVE EVIDENCE OF ACCEPTANCE OF THESE RESTRICTIONS.

WIRING DIAGRAM		MAPPS 300-265-12-120	
UNITS		DATE	
UNLESS OTHERWISE SPECIFIED: PRIMARY UNITS ARE: INCHES SECONDARY UNITS ARE: [mm]		18.FEB.19	
REVISIONS		APPROVALS NAME	
REV	REVISED BY	DATE	DATE
			18.FEB.19
MISC		DRAWN E. RIVAS	
		APPROVED C. LEONARD	
		22.FEB.19	
SCALE	DRAWING NUMBER	SIZE	
N/A	SD50-0507-SES	A	
	B.O.M. NUMBER		
	SB50-0507-SES		
SHEET 1 OF 3			

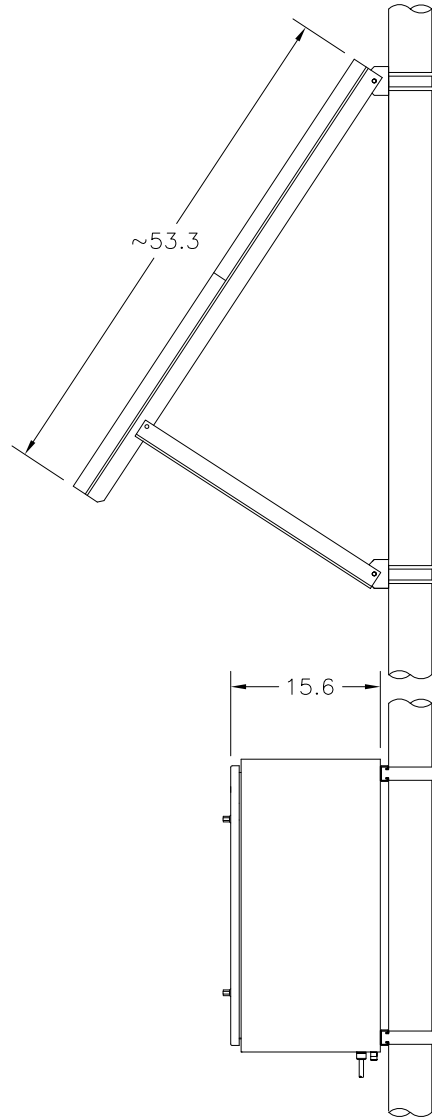
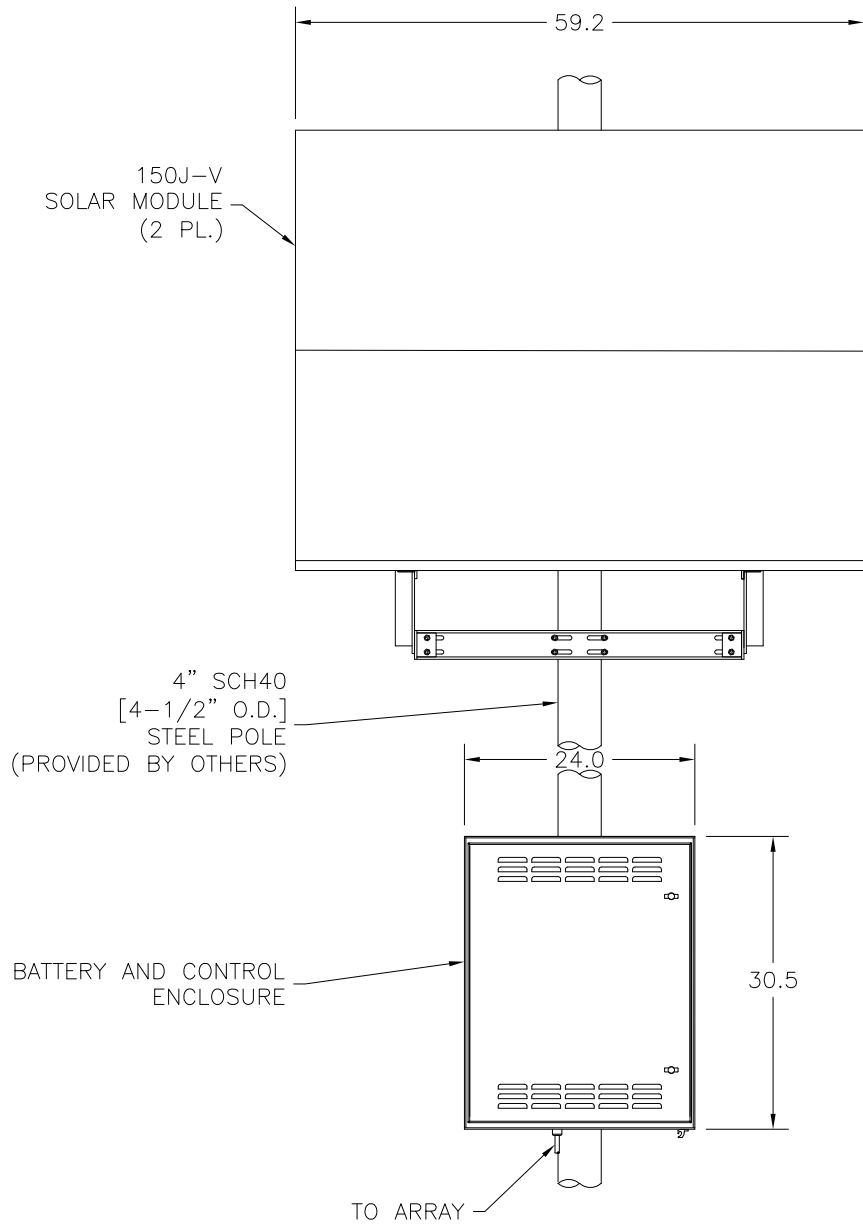

OWNERSHIP

COPYRIGHT ©2019 THE ABOVE DRAWINGS, SPECIFICATIONS, IDEAS, DESIGNS, AND ARRANGEMENTS ARE AND SHALL REMAIN THE PROPERTY OF SOLAR ELECTRIC SUPPLY AND NO PART THEREOF SHALL BE COPIED, DISCLOSED TO OTHERS, OR USED IN CONNECTION WITH ANY WORK OR PROJECT OTHER THAN THE SPECIFIED PROJECT FOR WHICH THEY HAVE BEEN PREPARED AND DEVELOPED WITHOUT THE WRITTEN CONSENT OF SOLAR ELECTRIC SUPPLY. VISUAL CONTACT WITH THESE PLANS OR SPECIFICATIONS SHALL CONSTITUTE CONCLUSIVE EVIDENCE OF ACCEPTANCE OF THESE RESTRICTIONS.

SITE LAYOUT		MAPPS 300-265-12-120	
UNITS		NAME	DATE
UNLESS OTHERWISE SPECIFIED: PRIMARY UNITS ARE: INCHES SECONDARY UNITS ARE: [mm]		DRAWN E. RIVAS	18.FEB.19
REVISIONS		APPROVED C. LEONARD	22.FEB.19
REV	REVISED BY	DATE	
APPROVALS		MISC	
SCALE	DRAWING NUMBER	SIZE	
N/A	SD50-0507-SES	A	
	B.O.M. NUMBER		
	SB50-0507-SES		
	SHEET 2 OF 3		

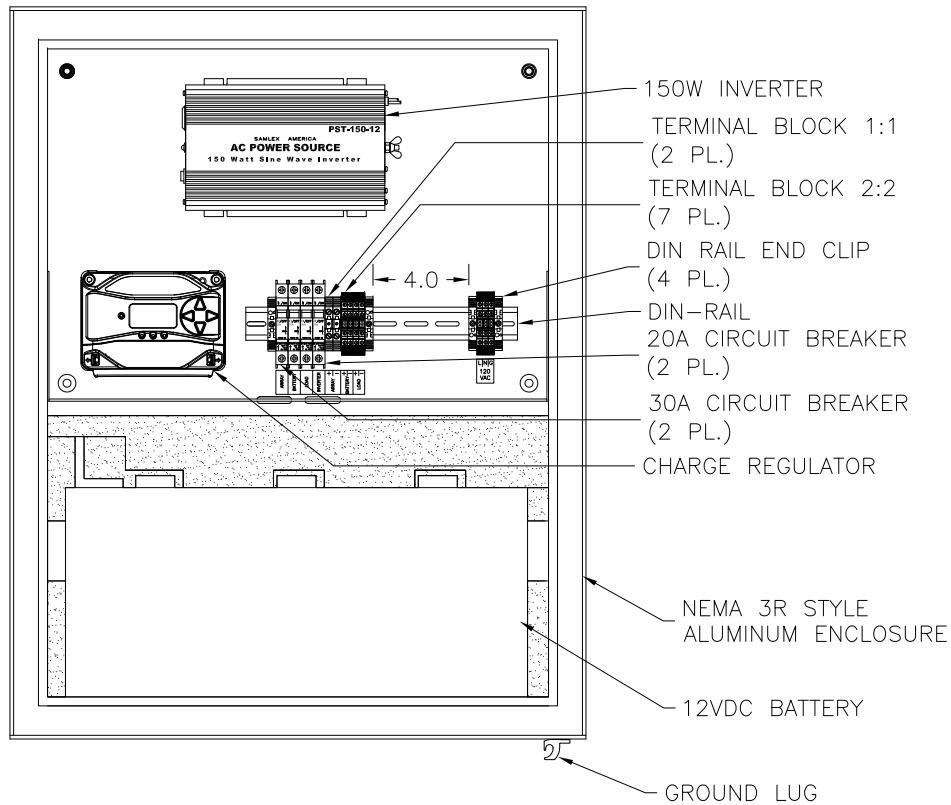

1. ENCLOSURE DOOR NOT SHOWN FOR CLARITY.
NOTES:



OWNERSHIP

COPYRIGHT ©2019 THE ABOVE DRAWINGS, SPECIFICATIONS, IDEAS, DESIGNS, AND ARRANGEMENTS ARE AND SHALL REMAIN THE PROPERTY OF SOLAR ELECTRIC SUPPLY AND NO PART THEREOF SHALL BE COPIED, DISCLOSED TO OTHERS, OR USED IN CONNECTION WITH ANY WORK OR PROJECT OTHER THAN THE SPECIFIED PROJECT FOR WHICH THEY HAVE BEEN PREPARED AND DEVELOPED WITHOUT THE WRITTEN CONSENT OF SOLAR ELECTRIC SUPPLY. VISUAL CONTACT WITH THESE PLANS OR SPECIFICATIONS SHALL CONSTITUTE CONCLUSIVE EVIDENCE OF ACCEPTANCE OF THESE RESTRICTIONS.

ENCLOSURE LAYOUT		DATE	
MAPPS 300-265-12-120		18.FEB.19	
UNITS		APPROVALS	
UNLESS OTHERWISE SPECIFIED: PRIMARY UNITS ARE: INCHES SECONDARY UNITS ARE: [mm]		NAME	DATE
REVISIONS		DRAWN E. RIVAS	18.FEB.19
REV	REVISED BY	DATE	APPROVED C. LEONARD
			22.FEB.19
MISC			
SCALE	DRAWING NUMBER	SIZE	
N/A	SD50-0507-SES	A	
	B.O.M. NUMBER		
	SB50-0507-SES		
	SHEET 3	OF 3	