

PVP75kW and PVP100kW

The new industry standard for reliability and ease of installation

The PV Powered 75kW and 100kW inverters set the industry standard for high reliability, ease of installation and lifetime maintainability. Their 20-plus year design-life is enabled by an array of new market-leading reliability features including bus bars for all power connections, a sealed electronics module and an instrumented cooling system. The highly-integrated system was designed to save commercial installers time and money with load break rated AC & DC service disconnects, certification for installation without a neutral conductor, cable landing points sized for maximum NEC-compliant cables and a well-planned cable bending radius for bottom and side cable entry options.

PV Powered commercial inverters offer best-in-class 96% efficiency and a voltage window of 295-600VDC. This is the widest operating range with the lowest standard MPPT voltage of any three-phase inverter in the industry. This provides exceptional stringing capability with all PV modules currently available including new thin film modules. Serviceability is enhanced by a modular design that divides the inverter into easy-to-maintain subsystems. PV Powered backs all their inverters with an industry-leading 10-year nationwide warranty and an unprecedented optional 20-year warranty, plus the best service and support team in the business.



PERFORMANCE MONITORING

Increase uptime and reduce maintenance costs with inverter-integrated monitoring solutions from market-leading third party partners. Each engineered solution is housed on a UL508A panel to deliver the highest level of safety and reliability. With the optional revenue grade meter and subcombiner monitoring, PV Powered offers unprecedented choice and convenience.



FEATURES

Superior Reliability

- Engineered power connections eliminate failure points
- Advanced, high-reliability circuit board system
- Redundant cooling system with Smart Air Management™
- Industrial-grade power supply for long-life and high quality control power

Exceptional Installability

- Bottom and side cable entry
- Generous cable bending area
- Complete range of fused DC sub-combiner options
- Exterior mounting flange for fast and easy anchoring
- Error-free AC auto-phasing

Easy to Maintain

- All maintenance and service via front access
- Load break rated AC and DC service disconnects
- Positive-locking, tool-free circuit board cage
- Optional preventative maintenance program and extended warranty



DIMENSIONS

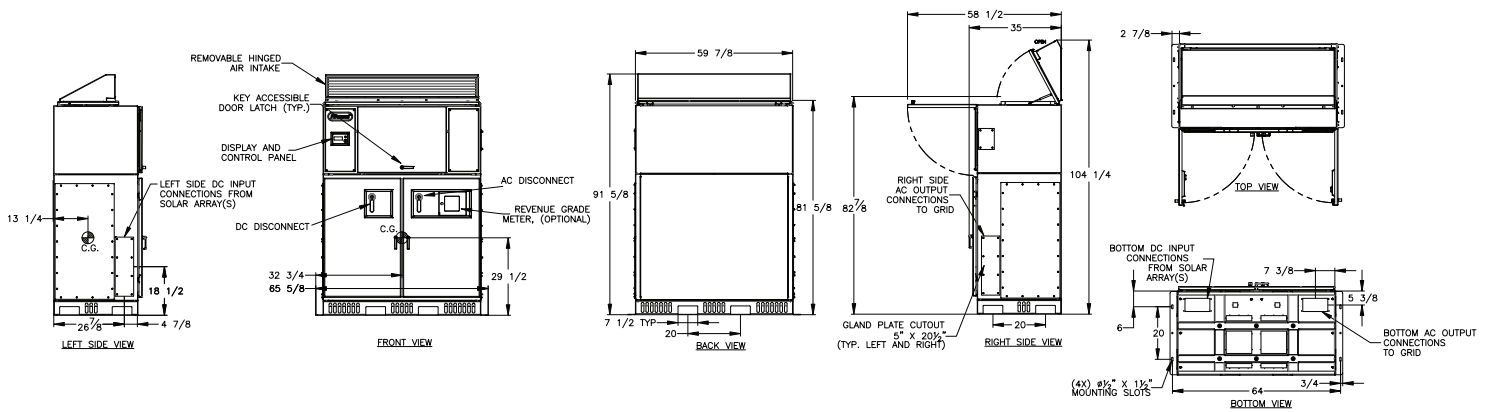

(complete design documentation including seismic calculations available upon request)

ELECTRICAL SPECIFICATIONS

MODEL	PVP75kW	PVP100kW
Continuous Output Power (kW)	75	100
Weighted CEC Efficiency (%)	95.5% (208 V), 95.5% (480 V)	95.5% (208 V), 96.0% (480V)
Maximum DC Input Voltage (VOC)	600	600
DC Peak Power Tracking Range (V)	295 - 595	295 - 595
DC Imp Nominal Current (A)	267	356
AC Nominal Voltage (V)	208Y, 480Y	208Y, 480Y
AC Operating Range (V)		
208	183 - 228	183 - 228
480	422 - 528	422 - 528
AC Frequency Range (Hz)	59.3 - 60.5	59.3 - 60.5
AC Maximum Continuous Current (A)	208 (208V), 90 (480V)	278 (208V), 120 (480V)
Standby Losses (W)	42	42
Harmonic Distortion (%THD)	< 3%	< 3%
Power Factor	>.99	>.99

MECHANICAL SPECIFICATIONS

MODEL	PVP75kW	PVP100kW
Enclosure	NEMA 4	NEMA 4
Construction	Powder Coated Steel	Powder Coated Steel
Mounting	Pad Mount	Pad Mount
Weight (lbs)	2,750	3,000
Cooling	Forced Convection	Forced Convection
Operating Ambient Temperature Range (°C)	-30 to 50	-30 to 50
Standby/Storage Ambient Temperature Range (°C)	-40 to 60	-40 to 60
Isolation Transformer	Yes	Yes

OPTIONS

- Complete range of integrated fused sub-array combiners from one to nine fuses and from 75 to 400 Amps
- Factory integrated data monitoring solutions
- Positive ground
- Preventative maintenance program
- 20-year warranty

STANDARDS APPROVALS

UL 1741, IEEE519, IEEE929, IEEE1547, CSA 107.1-1-1, FCC Class A for conducted and radiated



The PV Powered commercial inverter portfolio is now combined under AE's global service offerings.

