

ENERGIZING LIFE TOGETHER



INSTALLATION MANUAL

REC PEAK ENERGY SERIES

For installations according to UL 1703

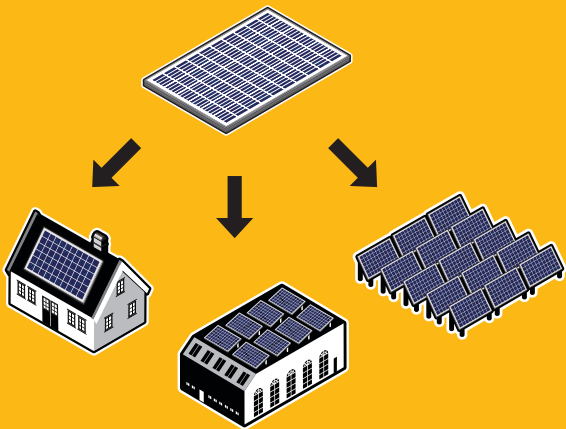

CONTENTS

| | |
|---|-----------|
| TABLE OF FIGURES | 2 |
| INTRODUCTION | 3 |
| HOW TO USE THIS MANUAL | 3 |
| YOUR RESPONSIBILITY AS AN INSTALLER | 3 |
| SUPPORT | 3 |
| LIABILITY DISCLAIMER | 3 |
| ELECTRICAL INSTALLATION | 4 |
| ELECTRICAL REQUIREMENTS | 4 |
| I) SYSTEM REQUIREMENTS | 4 |
| II) CONNECTION | 4 |
| III) STRING CONFIGURATION | 4 |
| IV) WIRING LAYOUT | 4 |
| V) JUNCTION BOX, CONNECTORS AND MATERIALS | 4 |
| VI) CABLE MANAGEMENT | 4 |
| VII) ELECTRICAL RATINGS | 4 |
| SAFETY MEASURES | 4 |
| I) SAFETY IN THE WORKING AREA | 4 |
| II) PREVENTING CURRENT GENERATION | 4 |
| III) SPECIFIC HAZARDS OF DC ELECTRICITY | 4 |
| IV) SAFETY REQUIREMENTS | 4 |
| MECHANICAL INSTALLATION | 5 |
| FIRE GUIDELINES | 5 |
| ORIENTATION | 5 |
| ENVIRONMENTAL FACTORS | 5 |
| PANEL HANDLING | 5 |
| MOUNTING THE PANELS | 6 |
| PANEL INSTALLATION | 6 |
| I) RAIL SPECIFICATIONS | 6 |
| II) CLAMP SPECIFICATION | 6 |
| III) MOUNTING HOLES | 7 |
| IV) SLIDE-IN SYSTEMS | 7 |
| V) DRAINAGE HOLES | 7 |
| VI) LONG SIDE MOUNTING USING CLAMPS | 8 |
| VII) SHORT SIDE MOUNTING USING CLAMPS | 8 |
| VIII) GROUNDING | 8 |
| MAINTENANCE | 9 |
| CLEANING INSTRUCTIONS | 9 |
| SYSTEM INSPECTION | 9 |
| RECYCLING | 9 |
| PANEL INFORMATION | 10 |
| TECHNICAL INFORMATION | 10 |
| DOCUMENT HISTORY | 11 |

TABLE OF FIGURES

| Number | Title | Page | Number | Title | Page |
|--------|-------------------------------|------|---------|------------------------------------|------|
| Fig. 1 | Panel mounting options | 6 | Fig. 7 | Drainage holes | 7 |
| Fig. 2 | Rail specifications | 6 | Fig. 8 | Long side mounting | 8 |
| Fig. 3 | Clamp specifications | 6 | Fig. 9 | Short side mounting | 8 |
| Fig. 4 | Panel secured at four points | 6 | Fig. 10 | Recommended grounding | 8 |
| Fig. 5 | Mounting holes | 7 | Fig. 11 | Panel dimensions | 10 |
| Fig. 6 | Mounting using mounting holes | 7 | Fig. 12 | Frame cross-section and dimensions | 10 |



Caution: Only qualified personnel should perform work on photovoltaic systems such as installation, commissioning, maintenance and repairs. Be sure to follow the safety instructions for all system components. Ensure relevant local codes and regulations for health and safety and accident prevention are observed.

INTRODUCTION

Thank you for choosing REC photovoltaic panels. REC Peak Energy panels are ideal for delivering long-lasting and reliable power output. The panels have been created through intelligent design and are manufactured to the highest quality and environmental standards. With correct installation and maintenance, REC panels will provide clean, renewable energy for many years.

Please read this entire manual carefully. It contains critical information on safety, as well as detailed instructions for installation, operation and maintenance of this panel. Failure to follow the procedures contained within will invalidate the warranty. Review all instructions and safety notes before working on the system. Failure to do so may lead to injury or damage to property.

HOW TO USE THIS MANUAL

This installation manual describes the installation procedures for the mounting of all REC's UL 1703 certified REC Peak Energy Series solar panels in a photovoltaic array. Review the entire manual before installing the panels and ensure you are working from the latest version. Throughout the manual, you will see the below icons which highlight important information or notes:

 **Indicates potential for damage to the array or property or personal safety.**

 **Indicates important notes on best practice to help with the installation or to avoid potential damage to the panels, array or property.**

For further information on installation procedures, please call your distributor or contact your local REC Solar office. Details available at www.recgroup.com.

YOUR RESPONSIBILITY AS AN INSTALLER

Installers are responsible for the safe and effective installation and operation of the photovoltaic system and for adhering to all local and national standards and regulations. Prior to installation, check all applicable regulations and permits concerning solar systems and ensure all local directives are observed.

- Ensure the REC panels are in a suitable condition for use and appropriate for the particular installation and environment
- Use only parts that convene to the specifications set out in this manual
- Ensure a safe installation of all aspects of the electrical array

 **All equipment should be properly maintained and inspected prior to use.**

SUPPORT

Do not attempt to install when you are unsure of the procedure or suitability. For questions or guidance with your installation, please call your distributor or contact your REC sales office, which can be found at: www.recgroup.com/en/contacts.

LIABILITY DISCLAIMER

REC SOLAR PTE. LTD. accepts no liability for the usability and functionality of its photovoltaic panels if the instructions in this guide are not followed. Since compliance with this guide and the conditions and methods of installation, operation, use and maintenance of the panels are not checked or monitored by REC SOLAR PTE. LTD., REC SOLAR PTE. LTD. accepts no liability for damage arising from improper application or incorrect installation, use, operation or maintenance. This does not apply to damages due to a panel fault, in cases of loss of life, bodily injury or damage to health or in the event of a grossly negligent breach of obligations on the part of REC SOLAR PTE. LTD. and/or in the event of an intentional or grossly negligent breach of obligations by a legal representative or vicarious agent.

ELECTRICAL INSTALLATION

ELECTRICAL REQUIREMENTS

i) System Requirements

REC panels are only for use where they meet the specific technical requirements of the complete system. Ensure other components do not cause mechanical or electrical damage to the panels.

ii) Connection

If panels are connected in series, they should have the same amp rating. If panels are connected in parallel, they should have the same voltage rating.

iii) String configuration

When using string configuration, plan and execute it according to inverter manufacturer's instructions. The number of panels connected to an inverter should be within the inverter voltage limits and operating range. Do not exceed the total system voltage permitted by the manufacturer, nor under any circumstance exceed the maximum system voltage of 600 V. The maximum reverse current is 15 A and the maximum series fuse rating is 15 A.

iv) Wiring layout

To minimize voltage surges (e.g. indirect lightning strikes), cables of the same string should be bundled together so loops are as small as possible. String configurations must be checked before commissioning. If open circuit voltage (V_{oc}) and short circuit current (I_{sc}) deviate from specification, this may indicate a configuration fault. Correct DC polarity should be observed at all times.

v) Junction box, connectors and materials

The panel junction box is rated IP67. All connectors and cables must be secure and tight as well as electrically and mechanically sound. UV-resistant cables and connectors approved for outside use must be used. Conductor gauge must ensure DC power losses (voltage drop) are kept to a minimum (< 1%). Observe all local regulations when selecting cables. For field connections, use minimum 12 AWG (4 mm²) or copper wires insulated for a maximum operating temperature of 90°C.

vi) Cable Management

Cables must be secured using UV-resistant cable ties or other sunlight-resistant device. Loose and unsecured cables should be protected from damage (e.g. mechanical, abrasion, sharp objects, animals). As far as possible, avoid exposing cables to direct sunlight and permanent tension.



REC prohibits any modification to the panel, including the cutting of cables in order to change the connector type or the opening of the junction box unless explicitly authorized by REC. Doing so will invalidate the warranty.

vii) Electrical Ratings

Under normal conditions, a photovoltaic panel is likely to experience conditions that produce more current and/or voltage than reported at STC. The requirements of the National Electric Code (NEC) in Article 690 must be followed to address these increased outputs. In installations not under the requirements of the NEC, the values of I_{sc} and V_{oc} marked on the panels must be multiplied by a factor of 1.25 when determining component voltage ratings, conductor ampacities, overcurrent device ratings and size of controls connected to the PV output.

SAFETY MEASURES

Wiring installation shall be in accordance with the NEC (or CSA C22.1, Safety Standard for Electrical Installations, Canadian Electrical Code, Part 1 where applicable). All relevant electrical installation codes and regulations should be observed for regulations on working at heights and fall protection.

i) Safety in the working area

Installation of REC Peak Energy panels may involve working on a roof. Ensure all local regulations regarding working at heights are followed. Before beginning work on a photovoltaic system, ensure all working surfaces are structurally sound and capable of bearing the weight of employees and required equipment. Remember to isolate the system from the grid before carrying out any maintenance or repair work.

ii) Preventing current generation

Solar panels automatically generate current (electricity) when exposed to light. To prevent this, shield the system with a non-transparent cover during installation, maintenance or repair work.

ii) Specific hazards of DC electricity

Solar panels generate direct current (DC). Once current is flowing, breaking or opening a connection (e.g. removing a DC cable from the inverter) can cause an electrical arc. Unlike low voltage AC wiring, DC arcs are not self-extinguishing. They are potentially lethal burn and fire hazards, capable of high temperatures that can destroy contacts and connectors:

- Follow panel and inverter manufacturers' installation, handling and operating instructions
- Remove/open the inverter AC fuse/circuit breaker before disconnecting from the public grid.
- Switch off or disconnect the inverter and wait for the time specified by the manufacturer before commencing work. High-voltage components need sufficient time to discharge.

iv) Safety requirements

The voltage produced by a single panel and panels connected in series (voltages added together) or in parallel (currents added together) can be dangerous. Although the fully insulated plug contacts on the panel's output cables provide touch-safe protection, the following points must be observed during handling to avoid the risk of sparking, fire hazards, burns and lethal electric shocks.

- Exercise extreme caution when wiring panels and look out for damaged or dirty cables etc.
- Never insert metallic or other conductive objects into plugs or sockets.
- Ensure that all electrical connections are completely dry before assembly.
- Keep all materials, tools and working conditions dry and tidy.
- Use appropriate safety equipment e.g. nonslip footwear, insulated gloves and insulated tools.
- Solar panels produce current when exposed to sunlight. Do not connect the system to the inverter during solar exposure.

MECHANICAL INSTALLATION

FIRE GUIDELINES

REC Peak Energy Series panels have a Class C, Type 1 Fire classification. Utilize the following fire safety guidelines when installing REC Peak Energy Series panels:

- Check with local authorities for fire safety guidelines and requirements for any building or structure on to which the panels will be installed.
- The system design should ensure that it can be easily accessed in the event of a building fire.
- Check with local authorities for applicable regulations concerning setbacks or other placement restrictions that may apply for roof-mounted arrays.
- The use of DC ground fault interrupters is recommended. This may also be required by local and national codes.
- All electrical appliances are a fire risk. The panel should therefore be mounted over a fire retardant roof covering rated for the application and a suitable distance of 4 in between the panel and the mounting surface, allowing free circulation of air beneath the panels, should be respected at all times.

ORIENTATION

To maximize system output, panels should be installed at the optimum orientation and tilt angle. The specifics of this depend on location and can be calculated by a qualified system designer. A lower angle of panel installation increases the requirement for regular cleaning.

The optimal mounting position of panels results in the sun's rays falling perpendicular (i.e. at 90°) to the surface. All panels in a string should, wherever possible, have the same orientation and tilt to ensure the system does not underperform due to mismatched outputs.

 **The panels should not be exposed to artificially concentrated sunlight.**

ENVIRONMENTAL FACTORS

REC Peak Energy Series panels are designed to provide decades of durable and stable output. Operating temperatures should be between -40 and 185°F (-40 and +85°C).

The panels are not suitable for installation in potentially hazardous locations nor should they be installed in the following locations:

- Near sources of flammable gases or vapors
- Near open flames.
- Under water or in water features.
- Where exposed to sulfur e.g. near sulfur springs or volcanoes.
- Where the panels may be exposed to harmful chemicals.

 **Ensure panels are not exposed to direct contact with salt water/spray and avoid installation in areas subject to high salt mist content e.g. coastal areas.**

PANEL HANDLING

Panels should be handled with care. All warnings and instructions on the packaging should be observed. Follow these guidelines when unpacking, transporting or storing the panels:

- Record the serial numbers prior to installation and note the information in the system documentation.
- Carry the panels using both hands and avoid using the junction box as a grip.
- Do not allow the panels to sag or bow under their own weight when being carried.
- Do not subject the panels to loads or stresses e.g., leaning or placing heavy objects on them.
- Do not stand on the panels or cause impact through dropping them.
- Keep all electrical contacts clean and dry.
- Store panels in a dry and properly ventilated room.
- Do not apply force to the backsheet.
- Avoid using sharp or pointed objects if panels require marking.
- Never apply paints, adhesives or detergents to the back of the laminate.
- Do not use any solar panel that is damaged or been tampered with.
- Never attempt to disassemble the panels.

 **If the panel front glass is broken or laminate back sheet is damaged, it can expose personnel to hazardous voltages.**

MOUNTING THE PANELS

REC Peak Energy Series panels are designed for capturing solar radiation and are not suitable for installation as overhead or vertical glazing. The panels are considered to be in compliance with UL 1703, only when the panel is mounted specified by the mounting instructions below. The REC junction box on the back of the panel is protected to IP67 and hence panels can be mounted in any orientation.

PANEL INSTALLATION

REC Peak Energy panels are typically installed on a rail-based mounting system. There are three different methods of installing an REC Peak Energy panel, each described below, depending on the design load of the array. The rails can run under the frame or parallel to the frame, directly under the clamping zones (fig 1a & 1b). Ensure the mounting structure is able to withstand anticipated wind and snow loads.

i) Rail specifications

Fig. 1: Panel mounting options

(a) Long side mounting using clamps

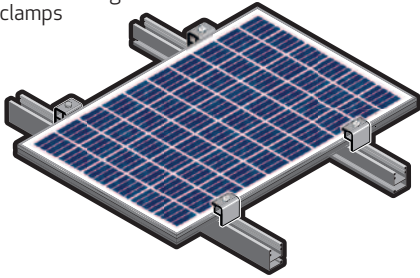

(b) Short side mounting using clamps

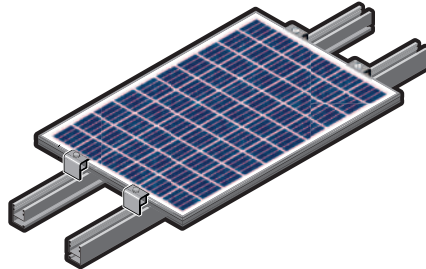

(c) Mounting holes

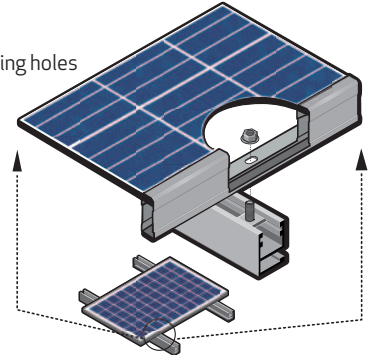

! Ensure a minimum distance of 4 in (10 cm) between the uppermost part of the roof and the lowest part of the panel to ensure sufficient airflow beneath the panels and aid cooling.

The clamps should be fastened to C or H channel rails (fig. 2).

- Thickness of walls for mechanical connections: min. 0.156 in (4.0 mm)
- Thickness of walls exposed to buckling load: min. 0.08 in (2.0 mm)
- Moment of Inertia for profile area about X-X: min array mounting diagram 0.4 in⁴ (19.2 cm⁴)

ii) Clamp Specification

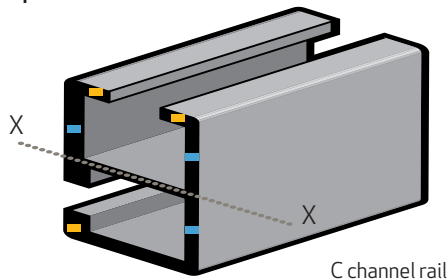

C channel rail

Fig. 2: Rail specification

- Walls for mechanical connectors
- Walls exposed to buckling load

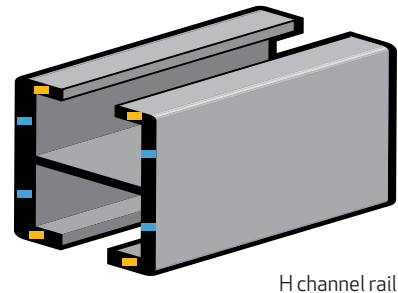

H channel rail

★ The overlap between support rail and the outer edge of the panel frame must be a minimum of 1/64 in (6 mm).

REC Peak Energy panels have been evaluated by UL for mounting using C-channel-rails in combination with end and mid clamps, 5/16 in (8 mm) ASTM F593C stainless steel screw and rail nuts. Alternatively clamps with the below ratings and dimensions can be used to secure the panel to the mounting structure (fig. 3):

- Minimum yield strength of 2089 ton/ft² (200 Mpa)
- Minimum tensile strength of 2610 ton/ft² (250 Mpa), e.g. 6005 T5 alloy.
- Minimum grip length of 1.75 in (44.45 mm)
- Minimum grip depth of 0.29 in (5 mm)
- Minimum thickness of load carrying walls of 0.156 in (4 mm)
- Screw connection – 5/16 in (8 mm) stainless steel bolt, 5/16 in split washer (8 mm), nut

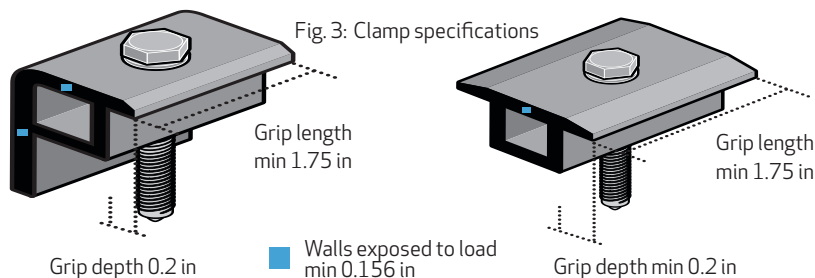

Fig. 3: Clamp specifications

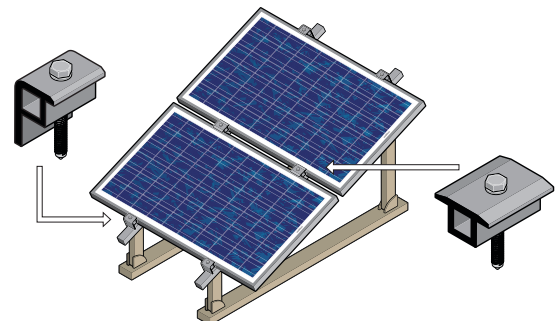

Fig. 4: An array mounting system with each panel secured at four points.

! Each panel must be securely fixed to the mounting structure at a minimum of four points (fig.4).

iii) Mounting holes

Mounting utilizing the four elongated holes (0.26 x 0.43 in (6.6 x 11 mm)) on the underside of the panel frame (at a distance of 17.72 in (450 mm) from the midpoint of the long side) have been found to comply with UL 1703 requirements for a maximum design load of 75.2 lbs/ft² (3600 Pa) (fig. 5).

When mounting using mounting holes, the frame and panel edge must be supported by two transverse rails (fig. 1, p 8), of aluminium or galvanized steel to avoid galvanic corrosion and be appropriate for the local environment. These must be held in position by bolts and flange nuts according to the specifications below. If bought in a kit, do not use the washers and bottom mounted clips provided:

! When using mounting holes, fixings must be fastened to 9 ft-lbs (12 Nm) of torque and installation must be according to fig. 6.

| Part Name | Material | Specification |
|------------|----------------------------|------------------|
| Bolt | ASTMF593 (stainless steel) | 1/4" x 20 - 5/8" |
| Flange Nut | ASTMF594 (stainless steel) | 1/4" x 20 |

! Install the above parts as shown in fig. 6. Consult the Unirac Code Compliant Installation Manual for further details where necessary. For areas where discrepancy may exist, this installation manual shall take precedence.

Fig. 5: Mounting holes

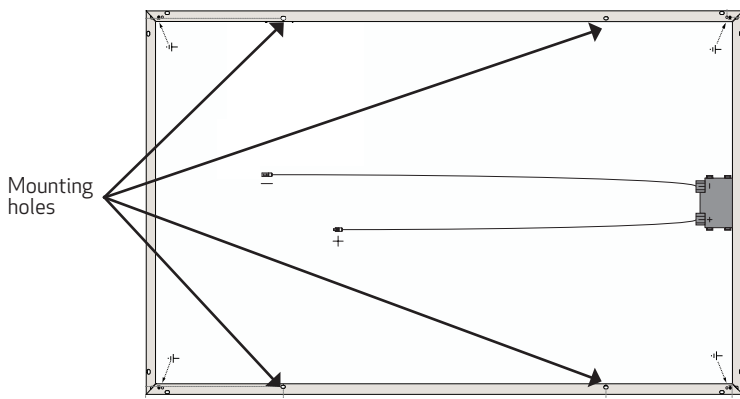
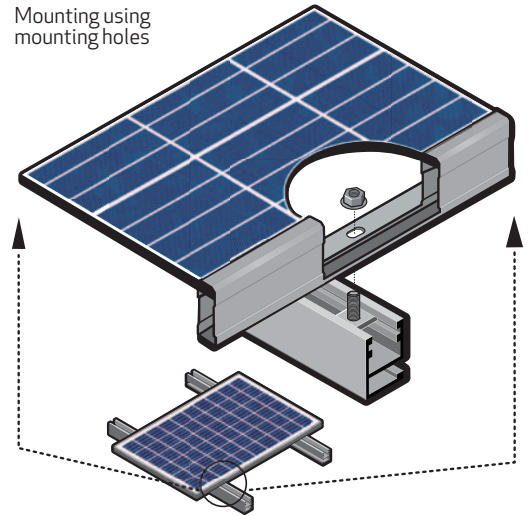

Fig. 6: Mounting using mounting holes



Observe the following procedures when using mounting holes (fig. 5):

- Additional electrical bonding to Earth is required for the support structure (see page 12).
- All four mounting holes in the frame must be used (for long or short-sided mounting orientation).
- Fixings must be tightened to 9 ft-lbs (12 Nm) using a torque wrench.

! The warranty will be voided if additional holes are made in the frame. All fixing and fastening materials should be corrosion resistant.

iv) Slide-in Systems

REC Peak Energy panels have not been certified by UL for use with slide-in type mounting systems. If you have any questions regarding a mounting system and its suitability for REC Peak Energy panels, please contact your local office for technical support.

v) Drainage holes

There are eight drainage holes, 0.47 x 0.30 in (12 x 7.5 mm) in the panels frame, each spaced 2.2 in (55 mm) from the corner of the panel frame (fig. 5). This allows water caused by rain or snow melt to exit the frame easily and minimizes the damage caused by freezing and thawing. Ensure these holes are not covered by any part of the mounting structure.

Fig. 7: Drainage holes

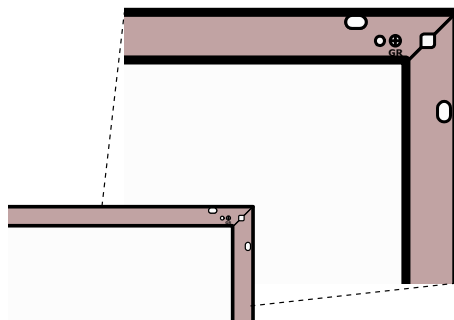

vi) Long side mounting using clamps

Mounting utilizing clamps on the two long sides of the panel have been found to be in compliance with UL 1703 requirements for a maximum design load of 75.2 lbs/ft² (3600 Pa) (fig. 8).

- Clamps must be secured between a distance of 8.2 in to 16.4 in (208 mm - 416 mm) from the corner of the panel (measured from the mid-point) to the clamp edge.
- Tightening torque must be tightened to 9 ft-lbs (12 Nm).
- The distance between the end clamp and the end of the rail must be minimum 1 in (25 mm).

Fig. 8: Long side mounting

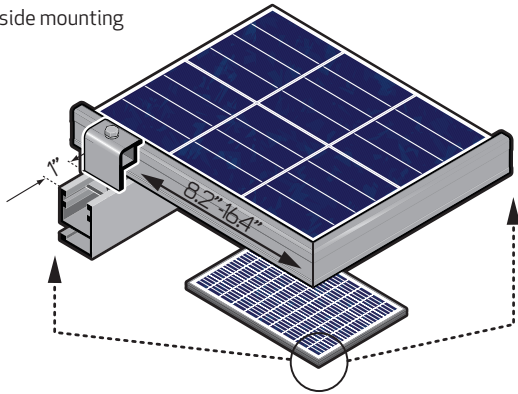
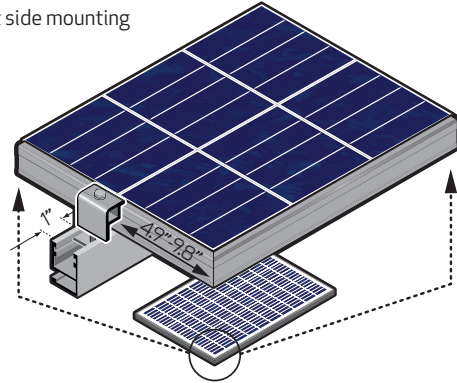

Fig. 9: Short side mounting



vii) Short side mounting using clamps

Mounting utilizing clamps on the two short sides of the panel have been found to be in compliance with UL 1703 requirements for a maximum design load of 33.4 lbs/ft² (1600 Pa) (fig. 9).

- Fix the panels so that the lower short side of the frame is supported by the mounting structure (to reduce risk of damages due to sliding snow load).
- Clamps must be secured between a distance of 4.9 and 9.8 inches (125 - 250 mm) from the panel corner to the clamp edge.
- Tightening torque must be tightened to 16 ft-lbs (21.7 Nm).
- The minimum distance between the end clamp and the end of the rail is 1 in (25 mm).
- Mechanical load must not exceed 33.4 lbs/ft (1600 Pa).
- The overlap between support rail and frame must be a minimum of 1/4 in (6 mm).

! In areas of snow build-up, panels can be subjected to forces in excess of the stated limit even when snow depth does not appear extreme, causing damage to the framework. If the installation is likely to be affected, further suitable panel support is recommended on the lower row of panels.

! Ensure the drainage holes are not covered by the mounting structure.

viii) Grounding

A panel with exposed conductive parts is considered to be in compliance with UL 1703 only when the it is electrically grounded in accordance with the instructions presented below and the requirements of the NEC. Grounding is achieved through securement to the panel frame of the following UL Listed grounding Clips / Lugs in combination with the REC Peak Energy panel(s).

- Suitable grounding lugs must be used: Listed (KDER) ILSCO, GBL-4DBT (tin plated) (E34440).
- Grounding cable size should be between 4 - 14 AWG (2.1 mm² - 21.2mm²).
- Attach grounds to the grounding holes in the panel frames.
- Fix lug to the frame using a star washer (#10) and lock nut (#10), ensuring a conductive connection (fig. 10). Tighten according to manufacturer's instructions.

! Where common grounding hardware (nuts, bolts, star washers, split-ring lock washers, flat washers and the like) are used to attach a listed grounding/bonding device, the attachment must be made in conformance with the grounding device manufacturer's instructions.

Fig. 10: Recommended grounding

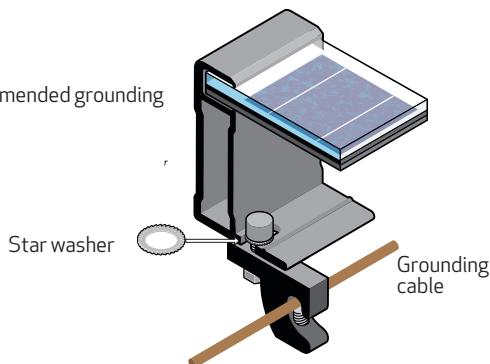

| Cross section [AWG] | Type | Torque [in-lbs] |
|---------------------|----------------|-----------------|
| 4 - 6 | Stranded | 35 |
| 8 | Stranded | 25 |
| 10 - 14 | Stranded/Solid | 2.8 |

Grounding lug dimensions and wire fastening torque for GBL-4DBT

★ To avoid galvanic corrosion, stainless steel fastening materials are preferred, however galvanized or hot dipped zinc plated fasteners are equally suitable.

MAINTENANCE

CLEANING INSTRUCTIONS

REC Peak Energy panels have been designed for easy maintenance. Normal rainfall will naturally clean the panels if installed at a sufficient angle. The need for cleaning will vary dependent on location, rainfall, pollution and angle of installation – the lower the angle of installation, the more cleaning will be required. To optimize electrical output it is recommended to clean the panels when dirt can be seen on the glass surface.



Cleaning of the panel should be carried out in the early morning when the panels are cool to avoid thermal shock.

If dirt remains on the panel, it may cause cell shading which will reduce power output or even cause further damage. To clean either the front or rear of the panels, use only deionized water at ambient temperature and a sponge, microfiber cloth or a soft brush to wipe away the dirt (rainwater, tap water or diluted alcohol may also be used as a secondary solution). For further cleaning a mild, biological and biodegradable washing-up liquid may be used.

When cleaning the panel, take care not to scratch the surface or introduce foreign elements that may cause damage. Ensure water used is free from grit and physical contaminants that may damage the panel. Always rinse the panel with plenty of water. If soiling remains, repeat the cleaning process. If stains require more effort to be removed, Iso-propyl alcohol of a concentration less than 10%. Acid or Alkali detergent may not be used



Use of high pressure hoses or cleaners is not permitted as these may damage the panel, laminate or cells.

Using a rubber squeegee, wipe the panel surface from the top downwards motion to remove any residual water from the panel glass. Panels can be left to dry in the air or wiped dry with a chamois. Avoid putting pressure on the panel surface when drying.

For more information on cleaning REC panels, consult the Cleaning Information Sheet available to download from the online REC Installer Portal www.recgroup.com/installers.

SYSTEM INSPECTION

The system should be inspected regularly to ensure that:

- Fasteners are secure, tight and free from corrosion.
- Electrical connections are secure, tight, clean, and free of corrosion.
- The mechanical integrity of the cables is intact.
- Bonding points to ground are tight, secure and free from corrosion (which could break the continuity between the panels and ground).

RECYCLING

REC has made every effort to ensure panel packaging is kept to a minimum. The paper and cardboard packaging can be recycled and the protective wrapping and panel separating blocks are also recyclable in many areas. Please recycle according to local guidelines and regulations.

PANEL INFORMATION

TECHNICAL INFORMATION

Fig. 11: Panel dimensions (in)

*Diagram indicates a generic junction box design, position may vary slightly.

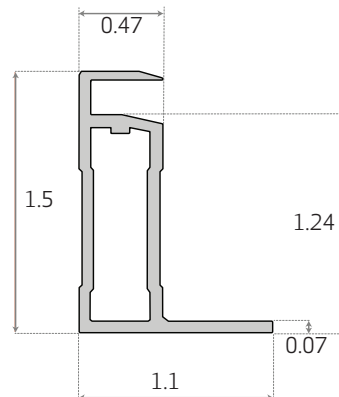
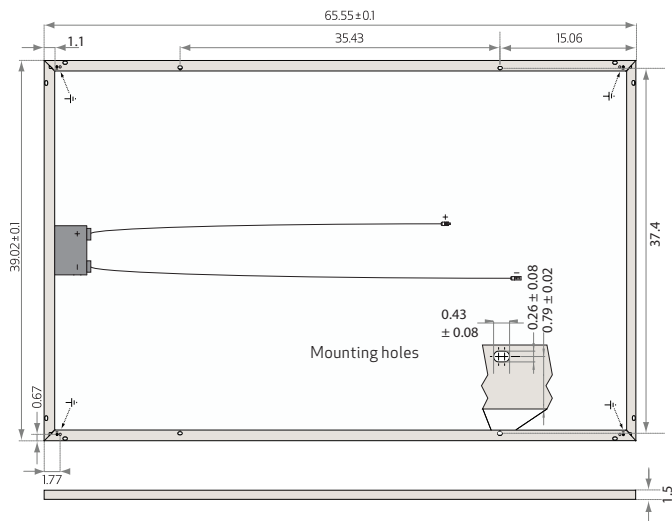

Fig. 12: Frame cross-section and dimensions (in)

MECHANICAL DATA

| | |
|-------------|------------------------|
| Dimensions: | 65.55 x 39.02 x 1.5 in |
| Area: | 17.76 ft ² |
| Weight: | 39.6 lbs |

MAXIMUM RATINGS

| | |
|--------------------------|--|
| Operational Temperature: | -40 ... +185°F (-40 ... +85°C) |
| Maximum System Voltage: | 600 V |
| Design Load: | 75.2 lbs/ft ² (3600 Pa)* 33.4 lbs/ft ² (1600 Pa)* |
| | *Dependent on mounting method as described above |
| Max Series Fuse Rating: | 15 A |
| Max Reverse Current: | 15 A |

GENERAL DATA

| | |
|---------------|---|
| Cell Type: | 60 REC PE multi-crystalline 6 x 6 in (156 x 156 mm) 3 sub-strings of 20 cells with bypass diodes |
| Glass: | 1/8" (3.2 mm) solar glass with anti-reflection surface treatment |
| Back Sheet: | Double layer highly resistant polyester |
| Frame: | Anodized aluminium |
| Junction Box: | IP67 rated 4 mm ² solar cable, 35" + 47" (0.9 + 1.2 m) |
| Connectors* | MC4 (4 mm ²) MC4 connectable (4 mm ²) Radox twist lock (4 mm ²) |
| | *Dependent on junction box design |

ELECTRICAL DATA @ STC

| | REC235* | REC240* | REC245* | REC250* | REC255* | REC260* | REC265* | REC270* |
|--|---------|---------|---------|---------|---------|---------|---------|---------|
| Nominal Power - P _{MPP} (Wp) | 235 | 240 | 245 | 250 | 255 | 260 | 265 | 270 |
| Watt Class Sorting - (W) | 0/+5 | 0/+5 | 0/+5 | 0/+5 | 0/+5 | 0/+5 | 0/+5 | 0/+5 |
| Nominal Power Voltage - V _{MPP} (V) | 29.5 | 29.7 | 30.1 | 30.2 | 30.5 | 30.7 | 30.9 | 31.3 |
| Nominal Power Current - I _{MPP} (A) | 8.06 | 8.17 | 8.23 | 8.30 | 8.42 | 8.50 | 8.58 | 8.66 |
| Open Circuit Voltage - V _{OC} (V) | 36.6 | 36.8 | 37.1 | 37.4 | 37.6 | 37.8 | 38.1 | 38.4 |
| Short Circuit Current - I _{SC} (A) | 8.66 | 8.75 | 8.80 | 8.86 | 8.95 | 9.01 | 9.08 | 9.18 |
| Panel Efficiency (%) | 14.2 | 14.5 | 14.8 | 15.1 | 15.5 | 15.8 | 16.1 | 16.4 |

The electrical characteristics are within +/-10 percent of the indicated values of I_{SC}, V_{OC} and P_{MPP} under standard test conditions (STC).

Values at STC (airmass AM 1.5, irradiance 1000 W/m², cell temperature 25°C).

At low irradiance of 200 W/m² (AM 1.5 and cell temperature 25°C) at least 97% of the STC panel efficiency will be achieved

* followed by PE, PE(BLK), PE ECO.

DOCUMENT HISTORY

| Date | Revision Number | Reason |
|-------------|------------------------|---|
| 01.2010 | A | First release |
| 02.2010 | B | Textual updates |
| 02.2010 | C | Textual updates |
| 03.2010 | D | Textual updates |
| 05.2010 | E | Textual updates |
| 07.2010 | F | Textual updates |
| 03.2011 | G | Textual updates, update of electrical data |
| 10.2012 | H | Release of separate IEC 61215/61730 and UL1703 specific installation manual version. |
| 01.2013 | H.2 | Textual update of technical characteristics |
| 01.2013 | H.3 | Correction of available grounding lug information |
| 02.2013 | I | Textual updates. Update of junction box and connector information in Technical Information |
| 04.2013 | I.2 | Addition of low watt classes (214 - 230 Wp) for UL records |
| 04.2013 | I.3 | Update of tightening torque for clamping and mounting holes. |
| 06.2013 | I.4 | Update of torque rating for long-side clamping and mounting holes. Addition of electrical data to 270Wp |
| 08.2013 | J | Addition of note prohibiting the cutting of cables |
| 11.2013 | K | Textual updates (Notes on panel handling, operating temperature) |
| 04.2014 | K.2 | Textual updates, update to Fire Classification (Class C, Type 1) |



REC SOLAR PTE. LTD.
20 Tuas South Avenue 14
Singapore 637312
Tel: +65 6495 9228
Mail: post@recgroup.com

www.recgroup.com