

SN 72-Cell Polycrystalline PV Module



SN300P-10 / SN305P-10 / SN310P-10 / SN315P-10
SN300P-15 / SN305P-15 / SN310P-15 / SN315P-15

300 ~ 315 Watt

Continuously manufacturing PV modules since 1991, S-Energy is one of the most experienced module makers in the industry. More than 20 years of operating data support S-Energy's reputation as the best overall quality, performance, and value for solar investors. The cutting-edge SN-series leads the industry again in advanced design, construction, and performance. The SN-series is the ideal module for any system size in any given environment. With the quality to last the lifetime of the PV system, S-Energy's SN-series provides the confidence and assurance to each and every one of our customers.



Features



ENHANCED EXTERNAL LOAD / IMPACT

Snow Load : 5,400 Pa
Wind Load : 2,400 Pa
Hail Impact : 30.7 m/s (speed ball)

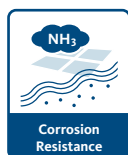

ENVIRONMENT RESISTANCE

Suitable for extreme conditions
Resistant to high salt mist and ammonia
(certified by TÜV Rheinland)



POWER ADVANTAGE

25-year, linear power warranty
> 97.5% nominal power during 1st year
Positive tolerance up to +5W



PID RESISTANCE

Enhanced potential induced degradation



FIRE SAFETY

UL1703 Fire Classification : Type 1, Type 2

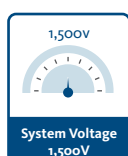

FIRST UL-CERTIFIED 1,500V MODULE

Optimized BOS cost allows a reduced system cost

Qualifications & Certifications

IEC 61215 & 61730, UL1703
ISO 9001, ISO 14001, OHSAS 18001



Mechanical Characteristics

Solar Cells	Polycrystalline 156mm x 156mm (6 inches)
Number of Cells	72 Cells, 6 x 12 matrix
Dimensions	1970 x 990 x 40 mm / 1985 x 999 x 40 mm
Weight	20 kg (44.09 lbs) / 20.5kg (45.19 lbs)
Front Glass	High-Transmittance Low Iron Tempered Glass
Frame	Anodized Aluminum Frame
Output Cables	PV Wire (PV1-F), 12AWG (4mm ²), Cable Length : 1200mm
Connectors	MC4 Connectable

Warranty

Product Warranty	10-year Limited Product Warranty
Performance Warranty	Minimum Power Output for Year 1 : 97.5%
	Maximum Power Decline from Year 2 to 24 : 0.7%
	Power Output at Year 25 : 80.7%

SN 72-Cell Polycrystalline PV Module



SN300P-10 / SN305P-10 / SN310P-10 / SN315P-10
 SN300P-15 / SN305P-15 / SN310P-15 / SN315P-15

Electrical Characteristics

STC (Irradiance 1000W/m ² , module temperature 25°C, AM=1.5)	SN300P-10/15	SN305P-10/15	SN310P-10/15	SN315P-10/15
Rated Power (P _{max})	300W	305W	310W	315W
Voltage at P _{max} (V _{mp})	35.6V	36.0V	36.3V	36.6V
Current at P _{max} (I _{mp})	8.44A	8.47A	8.54A	8.61A
Warranted Minimum P _{max}	300W	305W	310W	315W
Short-Circuit Current (I _{sc})	8.88A	8.90A	8.96A	9.01A
Open-Circuit Voltage (V _{oc})	44.9V	45.1V	45.4V	45.6V
Module Efficiency	15.38% / 15.13%	15.64% / 15.38%	15.89% / 15.63%	16.15% / 15.88%
Operating Module Temperature	-40°C to +85°C			
Maximum System Voltage	1000V _{DC} (UL) / 1500V _{DC} (UL)			
Maximum Series Fuse Rating	15A			
Maximum Reverse Current	20.25A			
Power Tolerance	0 ~ +5 W			

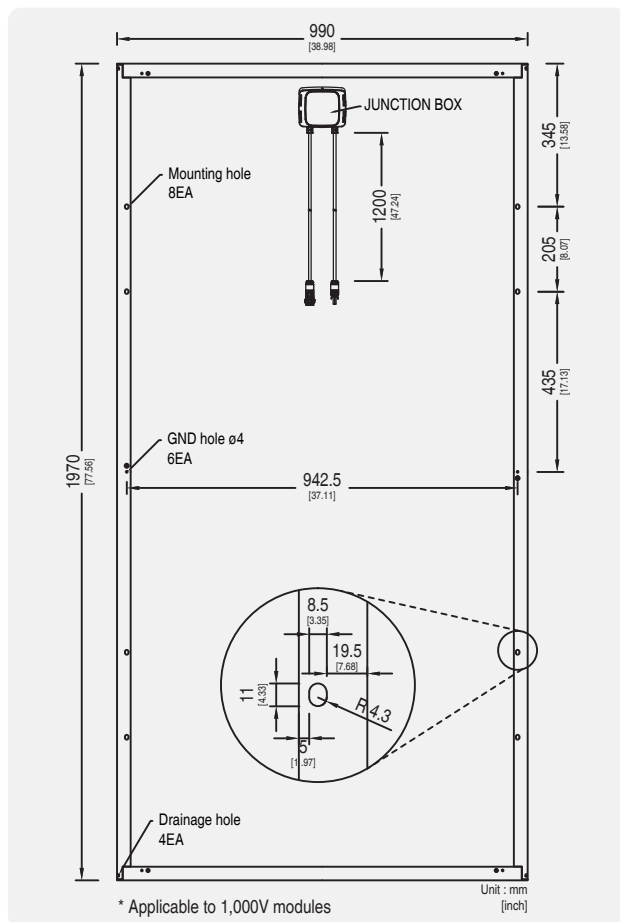

Temperature Characteristics

Temperature Coefficient of I _{sc}	0.056 / °C
Temperature Coefficient of V _{oc}	-0.301 / °C
Temperature Coefficient of Power	-0.398 / °C
NOCT (T _{air} 20°C ; Irradiance 800W/m ² ; Wind 1m/s)	45±2 °C

Packing Configuration

Container	40' H/C
Modules Per Pallet	25 pcs
Pallets Per Container	22 pallets
Modules Per Container	550 pcs

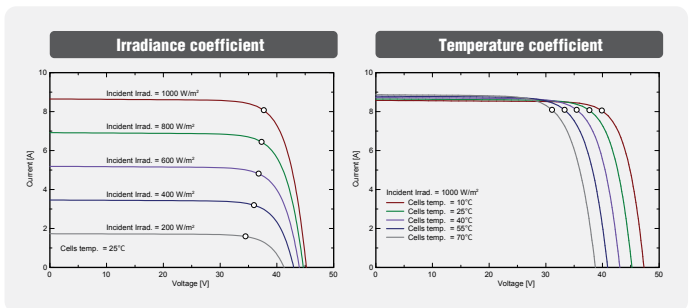

Remarks :

P_{max} measurement tolerance : ±2.5%
 S-Energy uses triple AAA class simulator.
 Specification subject to change without prior notice. S-Energy reserves the rights of final interpretation.
 Document : SE-Datasheet_SN 72-Cell_3BB_2015_US_V01

S-Energy Co., Ltd.

Address. 3rd Fl., Miraeasset Tower, 685, Sampyeong-dong, Bundang-gu, Seongnam-si, Gyeonggi-do 463-400, Republic of KOREA
 Tel. +82-70-4339-7100 Fax. +82-70-4339-7199 E-mail. inquiry@s-energy.com

SEAI America, Inc. (d.b.a. S-Energy America)

Address. 20 Corporate Park, Suite 190, Irvine, CA 92606, U.S.A.
 Tel. +1-949-281-7897 Fax. +1-949-281-7893 E-mail. sales.us@s-energy.com

S-Energy Japan Co., Ltd.

Address. 1-6-9, Koujimachi, Chiyoda-ku, Tokyo, DIK Koujimachi building 3F-A, Japan
 Tel. +81-3-6261-3759 Fax. +81-3-6261-3769 E-mail. toru.yasuda@s-energy.com