

PV Inverters

Use of PV inverters in off-grid systems and backup systems in North and South America

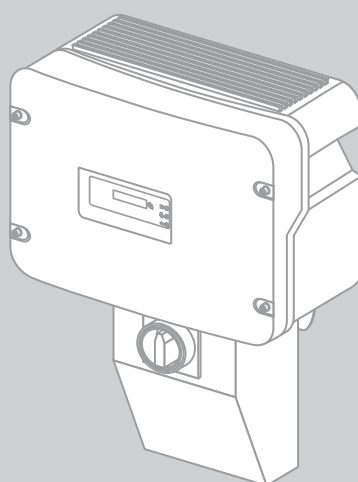

Table of Contents

Both in off-grid systems and in the event of grid failures in backup systems, grid fluctuations in the stand-alone grid are possible. This may cause severe deviations in nominal voltage and nominal frequency. Despite such fluctuations, all the components of the system must function without problems.

This technical information will inform you about the following topics:

- Which PV inverters you can use in off-grid systems and backup systems.
- Which parameters you need to set in the PV inverter.
- What type of communication you need to install in backup systems.
- Which values the parameters of PV inverters will display in off-grid operation.
- How the output power of the PV inverter can be limited by the Frequency-Shift Power Control function (FSPC) of the off-grid inverter.

1 Choosing the PV Inverter

You can use the following PV inverters in off-grid systems or backup systems:

PV inverter	Off-grid system	Backup system
Sunny Boy 700-U	✓	✗
Sunny Boy 1800-U	✓	✗
Sunny Boy 2100-U	✓	✗
Sunny Boy 2500-U	✓	✗
Sunny Boy 3300-U	✓	✗
Sunny Boy 3800-U	✓	✗
Sunny Boy 6000-U	✓	✗
Sunny Boy 3000-US	✓	✓
Sunny Boy 4000-US	✓	✓
Sunny Boy 5000-US	✓	✓
Sunny Boy 6000-US	✓	✓
Sunny Boy 7000-US	✓	✓
Sunny Boy 8000-US	✓	✓
Sunny Boy 2000HF-US	✗	✗
Sunny Boy 2500HF-US	✗	✗
Sunny Boy 3000HF-US	✗	✗
Sunny Boy 3000TL-US	✓	✓**
Sunny Boy 4000TL-US	✓	✓**
Sunny Boy 5000TL-US	✓	✓**
Sunny Boy 6000TL-US	✓	✓
Sunny Boy 7000TL-US	✓	✓
Sunny Boy 8000TL-US	✓*	✓*
Sunny Boy 9000TL-US	✓*	✓*
Sunny Boy 10000TL-US	✓*	✓*
Sunny Boy 11000TL-US	✓	✓

* Compatible as of device type SB XXXXTLUS-12

** Compatible as of device type SB XXXXTLUS-22

✓ Compatible

✗ Not compatible

i System failures due to excessive power output of AC sources in the stand-alone grid

If the power of the AC sources (e.g., PV inverters) in off-grid systems or backup systems is too high, it may cause system failures.

- Design the total nominal AC power of the PV inverters to be no more than twice as high as the nominal AC power of the off-grid inverters.
- If wind energy inverters feed into the stand-alone grid, design the total nominal power of the AC sources in the stand-alone grid to be no larger than the nominal AC power of the off-grid inverters.
- Per 1 000 W nominal AC power of the AC sources in the stand-alone grid, allow at least 100 Ah battery capacity.

2 Configuration of the PV Inverters

2.1 Configuration Options

WARNING

Danger to life due to electric shock

If the power distribution grid fails, there is a risk of backfeed in PV inverters which are configured for off-grid operation.

- Find out about the standards and guidelines applicable to off-grid systems and backup systems at your location.
- Only operate PV inverters configured for off-grid operation in off-grid systems or backup systems.
- Coordinate the parameter settings for PV inverters and Sunny Island inverters with the respective grid operator.

Configuration with Communication Products

Code required to change grid-relevant parameters

To change the grid-relevant parameters in the PV inverter, you need a special code. To obtain this code, contact SMA America, LLC on +1 916 625 0870.

You can configure the PV inverters with the following communication products:

PV inverter	Sunny Boy Control	Sunny WebBox	Computer with Sunny Data / Sunny Data Control software
Sunny Boy 700-U	✓	✓	✓*
Sunny Boy 1800-U	✓	✓	✓*
Sunny Boy 2100-U	✓	✓	✓*
Sunny Boy 2500-U	✓	✓	✓*
Sunny Boy 3300-U	✓	✓	✓*
Sunny Boy 3800-U	✓	✓	✓*
Sunny Boy 6000-U	✓	✓	✓*
Sunny Boy 3000-US	✓	✓	✓*
Sunny Boy 4000-US	✓	✓	✓*
Sunny Boy 5000-US	✓	✓	✓*
Sunny Boy 6000-US	✓	✓	✓*
Sunny Boy 7000-US	✓	✓	✓*
Sunny Boy 8000-US	✓	✓	✓*
Sunny Boy 3000TL-US	✓	✓	✓*

PV inverter	Sunny Boy Control	Sunny WebBox	Computer with Sunny Data / Sunny Data Control software
Sunny Boy 4000TL-US	✓	✓	✓ *
Sunny Boy 5000TL-US	✓	✓	✓ *
Sunny Boy 6000TL-US	✓	✓	✓ *
Sunny Boy 7000TL-US	✓	✓	✓ *
Sunny Boy 8000TL-US	✓	✓	✓ *
Sunny Boy 9000TL-US	✓	✓	✓ *
Sunny Boy 10000TL-US	✓	✓	✓ *
Sunny Boy 11000TL-US	✓	✓	✓ *

* You will also need a service cable for data transmission (USB Service Interface, SMA order number: USBPBS).

✓ Compatible ✗ Not compatible

You can configure the PV inverters for off-grid operation with the parameters "Default"/"CntrySet" and "BackupMode"/"Op.BckOpMod" (see installation manual of the respective communication product).

2.2 Parameter Setting for Off-grid Operation

The parameters "Default"/"CntrySet" and "BackupMode"/"Op.BckOpMod" are used to set the PV inverters to off-grid operation. With the "Default"/"CntrySet" parameter, you can set the country data set. With the "BackupMode"/"Op.BckOpMod" parameter you can set whether the PV inverter is to form a backup system with the off-grid inverter via RS485.

PV inverters in an off-grid system not connected to the power distribution grid must be configured according to the following table:

PV inverter	Parameters			
	"Default"	"CntrySet"	"BackupMode"	"Op.BckOpMod"
Sunny Boy 700-U	Off-Grid	-	-	-
Sunny Boy 1800-U	Off-Grid	-	-	-
Sunny Boy 2100-U	Off-Grid	-	-	-
Sunny Boy 2500-U	Off-Grid	-	-	-
Sunny Boy 3300-U	Off-Grid	-	-	-
Sunny Boy 3800-U	Off-Grid	-	-	-
Sunny Boy 6000-U	Off-Grid	-	-	-
Sunny Boy 3000-US	Off-Grid	-	Off	-
Sunny Boy 4000-US	Off-Grid	-	Off	-
Sunny Boy 5000-US	Off-Grid	-	Off	-
Sunny Boy 6000-US	Off-Grid	-	Off	-
Sunny Boy 7000-US	Off-Grid	-	Off	-
Sunny Boy 8000-US	Off-Grid	-	Off	-
Sunny Boy 3000TL-US	-	OFF-Grid60**	-	Off
Sunny Boy 4000TL-US	-	OFF-Grid60**	-	Off
Sunny Boy 5000TL-US	-	OFF-Grid60**	-	Off
Sunny Boy 6000TL-US	Off-Grid	-	Off	-
Sunny Boy 7000TL-US	Off-Grid	-	Off	-
Sunny Boy 8000TL-US	Off-Grid*	-	Off*	-
Sunny Boy 9000TL-US	Off-Grid*	-	Off*	-
Sunny Boy 10000TL-US	Off-Grid*	-	Off*	-
Sunny Boy 11000TL-US	Off-Grid	-	Off	-

* Can be adjusted as of device type SB XXXXTLUS-12

** At 50 Hz "OFF-Grid50"

2.3 Parameter Settings for Back-up Operation

In a backup system, the off-grid inverter is connected to the power distribution grid and communicates with the PV inverters via RS485. Therefore, you must equip the off-grid inverter and each of the PV inverters with an RS485 Piggy-Back. In a cluster, only the master of the off-grid inverter must be equipped with an RS485 Piggy-Back.

The parameters "Default"/"CntrySet" and "BackupMode"/"Op.BckOpMod" are used to set the PV inverters to off-grid operation. With the "Default"/"CntrySet" parameter, you can set the country data set. With the "BackupMode"/"Op.BckOpMod" parameter you can set whether the PV inverter is to form a backup system with the off-grid inverter via RS485.

The PV inverters must be configured according to the following table:

PV inverter	Parameters			
	"Default"	"CntrySet"	"BackupMode"	"Op.BckOpMod"
Sunny Boy 3000-US	UL1741	-	On all**	-
Sunny Boy 4000-US	UL1741	-	On all**	-
Sunny Boy 5000-US	UL1741	-	On all**	-
Sunny Boy 6000-US	UL1741	-	On all**	-
Sunny Boy 7000-US	UL1741	-	On all**	-
Sunny Boy 8000-US	UL1741	-	On all**	-
Sunny Boy 3000TL-US	-	UL1741	-	OnAllPhs**
Sunny Boy 4000TL-US	-	UL1741	-	OnAllPhs**
Sunny Boy 5000TL-US	-	UL1741	-	OnAllPhs**
Sunny Boy 6000TL-US	UL1741	-	On all**	-
Sunny Boy 7000TL-US	UL1741	-	On all**	-
Sunny Boy 8000TL-US	UL1741*	-	On all***	-
Sunny Boy 9000TL-US	UL1741*	-	On all***	-
Sunny Boy 10000TL-US	UL1741*	-	On all***	-
Sunny Boy 11000TL-US	UL1741	-	On all**	-

* Can be adjusted as of device type SB XXXXTLUS-12

** Even when the "BackupMode" or "Op.BckOpMod" parameter of the PV inverter is set to "OnAll" or "OnAllPhs", the system fulfills the requirements according to UL1741.

*** Even when the "BackupMode" parameter of the PV inverter is set to "On all", the system fulfills the requirements according to UL1741. The parameter "BackupMode" can be adjusted as of device type SB XXXXTLUS-12.

PV inverters without the "BackupMode" parameter

For PV inverters without the "BackupMode" parameter, the "Default" parameter must be set to "UL1741". After these settings have been made, the PV inverter is configured for operation on the power distribution grid. In the event of a power distribution grid failure, the off-grid inverter is no longer able to regulate the PV inverters by means of Frequency-Shift Power Control (FSPC). If there is an excessive supply of energy, the PV inverters will disconnect.

Backup systems with SI 4548-US-10, SI 5048U and SI 6048-US-10

In the event of a power distribution grid failure, the off-grid inverter sets the "Default"/"CntrySet" parameter of the PV inverter to "OFF_Grid". Thus, if a grid failure occurs, the off-grid inverter is able to regulate the PV inverters via Frequency Shift Power Control (FSPC). When the grid returns, the off-grid inverter sets the "Default"/"CntrySet" parameter of the PV inverter back to "UL1741".

Backup systems with SI 4248U

For operation with PV inverters, you must set the "Sunny Boy" parameter of the SI 4248U to **Yes** and the "GridConnected" parameter to **GridFeedPV**.

In the event of a power distribution grid failure, the SI 4248U regulates the power of the PV inverters directly via RS485.

3 Values of the Parameters in Off-grid Operation

The setting of the "Default" parameter to "OFF_Grid" automatically sets the PV inverter parameters to the values listed in the following table:

Parameters	Unit	Value
Test current	mA	Off (MSD=0)
Vac.Min	V	106 (-12% Vac nom)
Vac.Max	V	132 (+10% Vac nom)
Fac-delta- Lower range in which the Sunny Boy is active relative to f_0	Hz	-3.0 (starting from the base frequency f_0)
Fac-max+ Upper range in which the Sunny Boy is active relative to f_0	Hz	+3.0 (starting from the base frequency f_0)
dFac-Max Max. rate of change	Hz	4
Fac-start delta Frequency increase relative to f_0 , at which point the power adjustment via frequency begins.	Hz	1 (starting from the base frequency f_0)
Fac-limit delta Frequency increase relative to f_0 , at which point the power adjustment via frequency ends. The output power of the Sunny Boy at this point is 0 W.	Hz	2 (starting from the base frequency f_0)

4 Frequency-Shift Power Control (FSPC)

If PV inverters are connected on the AC side in off-grid operation or back-up operation, the Sunny Island must be able to limit their output power. This situation can occur when, for example, the Sunny Island's batteries are fully charged and the PV power available from the PV array exceeds the power required by the connected loads.

To prevent the excess energy from overcharging the battery, the Sunny Island recognizes this situation and changes the frequency at the AC output. This frequency change is analyzed by the PV inverter. As soon as the power frequency increases beyond the value specified by "f_{AC} Start delta", the PV inverter limits its output power accordingly.

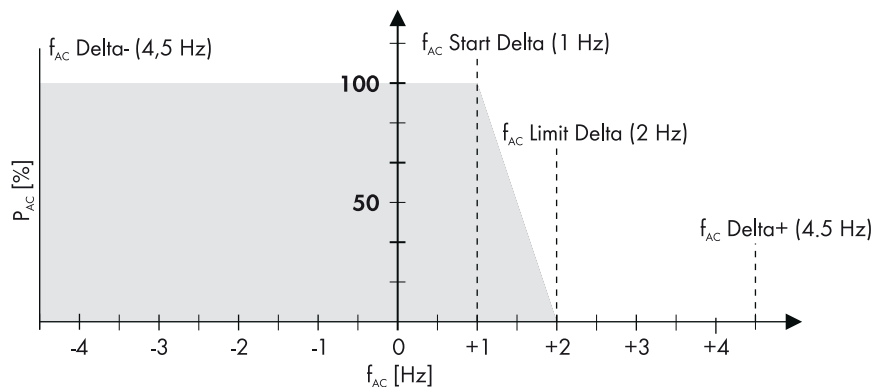

Figure 1: Operating principle of the FSFC

The terms used here have the following meanings:

- f_{AC} refers to the base frequency of the stand-alone grid (here 60 Hz).
- f_{AC} Delta- and f_{AC} Delta+ refer to the maximum range relative to f_{AC} in which the PV inverter is active.
- f_{AC} Start Delta is the frequency increase relative to f_{AC} , at which point the frequency-based power control begins.
- f_{AC} Limit Delta is the frequency increase relative to f_{AC} , at which point the frequency-based power control ends. The output power of the PV inverter at this point is 0 W.

If the value is below the f_{AC} Delta- limit or above the f_{AC} Delta+ limit, the PV inverters disconnect from the power distribution grid.

When an external energy source, (e.g., a diesel generator) is operating in the stand-alone grid, this external energy source determines the frequency, and the PV inverters set to off-grid operation react to certain frequency changes brought about by the external energy source.

When diesel generators are used as external energy source, the output voltage frequency under load is 60 Hz. For this reason, in most cases the PV inverters will deliver their entire power to the stand-alone grid, even when the diesel generator is in operation.

If the current battery voltage (V_{Bat}) is greater than the nominal battery voltage ($V_{Bat nom}$) and is also to be synchronized with an external energy source, the Sunny Island temporarily increases the frequency and the PV inverters disconnect via frequency shutdown (overfrequency). Afterwards, the Sunny Island synchronizes with the external energy source.